



YOSHIMURA

RESEARCH&DEVELOPMENT OF AMERICA, INC.

5420 DANIELS STREET STE A, CHINO CA., 91710 · (800) 634-9166 · (909) 628-4722 · FAX (909) 591-2198

www.yoshimura-rd.com

FENDER ELIMINATOR KIT

070BG111001
SUZUKI GSX-S1000(F)

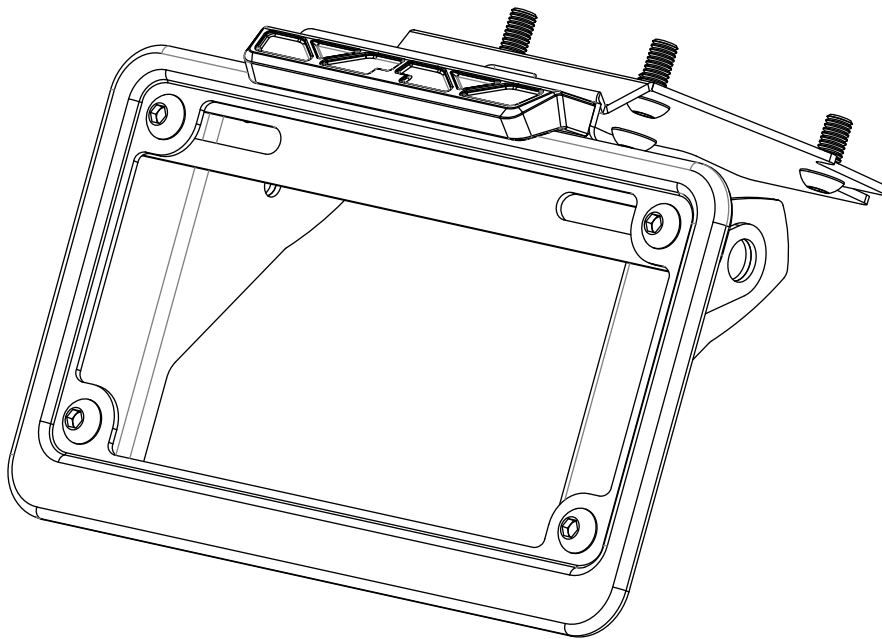

THIS PRODUCT IS NOT DOT APPROVED.

Yoshimura R&D of America, Inc. is not liable or responsible for any resulting event caused by the installation of this product. Check with local laws and regulations for compliance prior to installation and use. This product is not intended for use on public highways.



Assembly Diagram

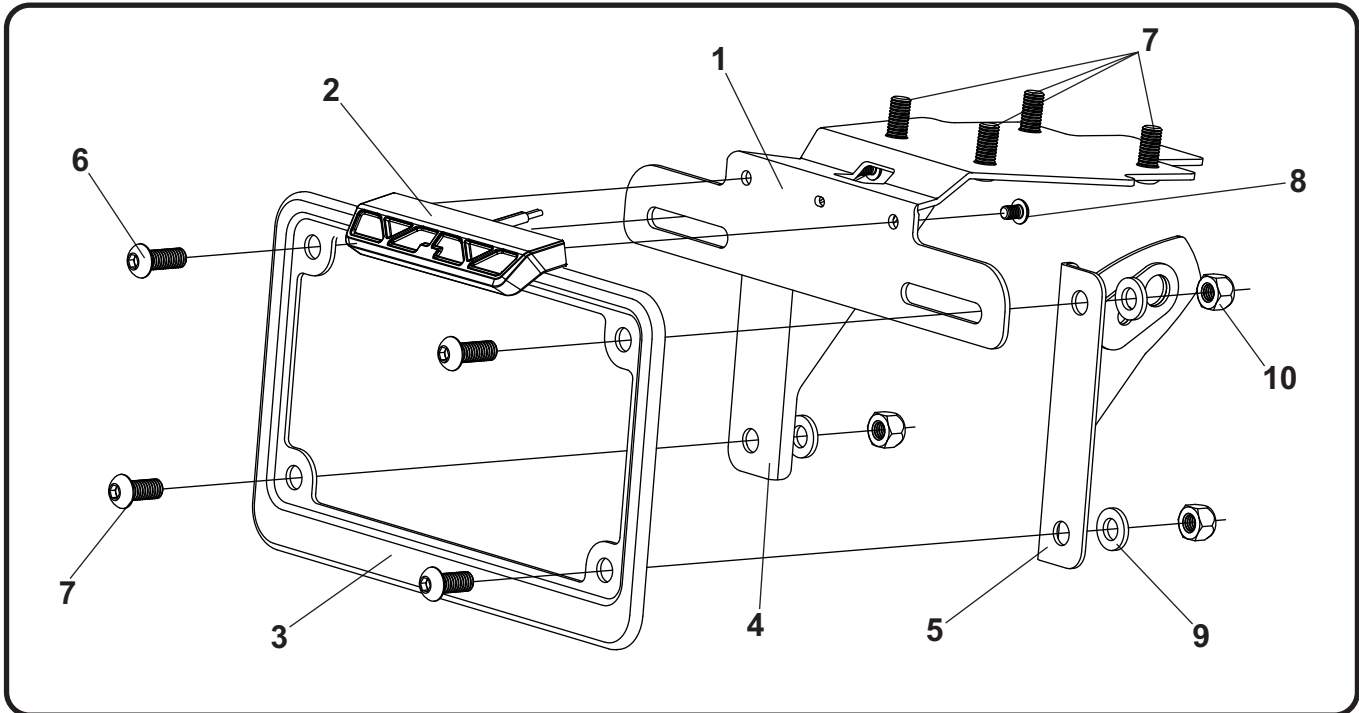

| No. | Item | Description | Qty. |
|-----------------------|--------------|-----------------------------------|------|
| 1 | 11100-FEBKT | Fender Eliminator Bracket | 1 |
| 2 | 070BG-LH-K1 | LED License Plate Light | 1 |
| 3 | 070BG-LPF | License Plate Frame | 1 |
| 4 | 11100-TSB-L | Left Turn Signal Bracket | 1 |
| 5 | 11100-TSB-R | Right Turn Signal Bracket | 1 |
| 6 | M6X16BHS | 6mm x 16mm Button Head Screw | 2 |
| 7 | M6X14BHS | 6mm x 14mm Button Head Screw | 6 |
| 8 | M4X6BHS | 4mm x 6mm Button Head Screw | 2 |
| 9 | 6MMWASHER | 6mm Washer | 4 |
| 10 | 6MMLN | 6mm Nylon Lock Nut | 4 |
| ** | BN-SSS-22-18 | Butt Connectors | 2 |
| ** | ZT-400 | Cable Ties | 3 |
| ** | 17029 | Yoshimura Sticker Sheet | 1 |
| Optional Parts | | | |
| *** | 070BGUNVTBKT | Universal Turn Signal Bracket Kit | |

*** The Yoshimura Universal Turn Signal Bracket Kit is to be used with aftermarket stud-mounted turn signals and is sold separately.

Removal

1. Remove passenger seat and rider seat.
2. Locate and disconnect the license plate light and turn signal connectors.
3. While securely supporting the stock fender assembly, remove the four bolts securing the fender assembly to the frame. Carefully remove the stock fender assembly making sure not to damage the connectors in the process.
4. Remove the left and right turn signals from the stock fender assembly.
5. Cut the stock license plate light connector from the stock fender assembly. Be sure to cut at least a 6" section of wire from the connector.

Installation

1. Install (No. 2) *070BG-LH-K1*, Yoshimura license plate light onto (No. 1) *11100-FEBKT*, Yoshimura fender eliminator bracket using (No. 8) *M4X6BHS*, 4mm button head screws provided in the kit.

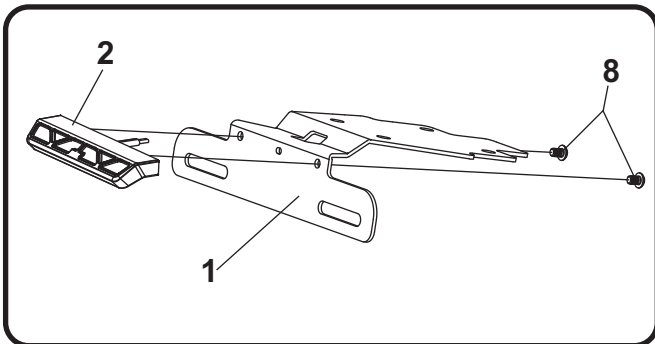

2. Install (No. 1) *11100-FEBKT*, fender eliminator bracket using (No. 7) *M6X14BHS*, 6mm button head screws. Route wires through hole in the bracket and beneath the passenger seat.

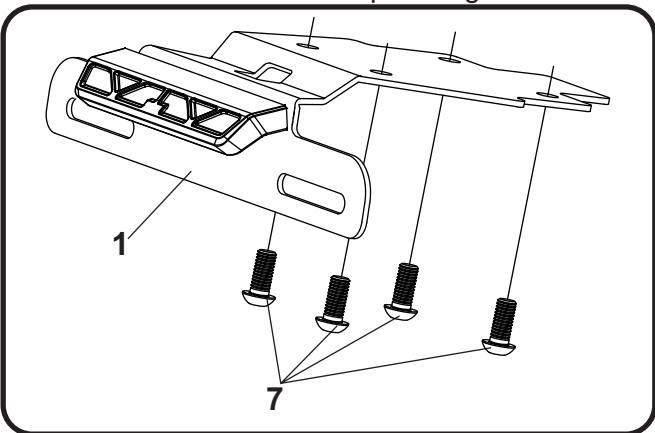

3. Due to both of the stock license plate light wires being black, determine the positive and negative wire by re-connecting the license plate light connector. Using the *BN-SSS-22-18* butt connectors provided in the kit, connect the Yoshimura license plate light wires to the stock license plate light wires as follows:

Brown (harness) -to- Red
Black/White (harness) -to- Black

- a) Strip the stock fender light wire ends 1/4" - 1/2" and insert into *BN-SSS-22-18*, butt connectors provided in the kit.
- b) Center the spliced wire ends in the middle and using a heatgun or lighter, apply heat evenly on the outer edges of the butt connector to shrink and hold wires in place.
- c) Making sure that the stripped ends are centered, heat the center of the butt connector evenly until the solder begins to liquify.
- d) Allow to cool completely and tug both ends of the wires to verify that connection is secured.

Scan for link to butt connector instruction video.

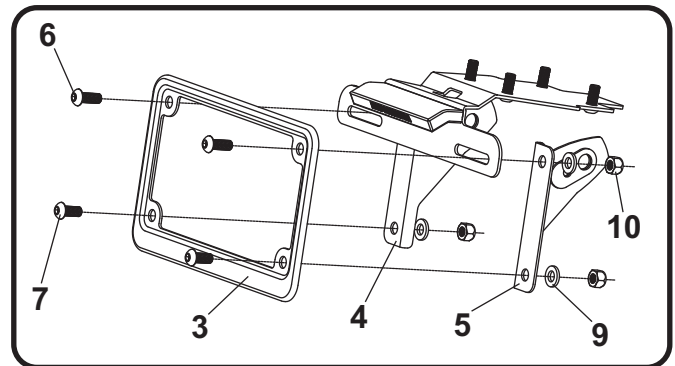

4. Install stock left and right turn signals onto (No. 4,5) *11100-TSB-L/R*, left and right turn signal brackets.

5. Install (No. 4,5) *11100-TSB-L/R*, left and right turn signal brackets and (No. 3) *070BG-LPF*, license plate frame using the (No. 6,7) *M6X16BHS* and *M6X14BHS*, 6mm button head screws as shown below.
6. Use the cable ties provided in the kit to secure license plate light and turn signal wires beneath passenger seat.
7. Re-install rider and passenger seat.
8. Check for proper function of license plate light, turn signals, brake light, and that all brackets and components are secure prior to riding.