



YOSHIMURA

RESEARCH&DEVELOPMENT OF AMERICA, INC.

5420 DANIELS STREET STE A, CHINO CA., 91710 · (800)634-9166 · (909)628-4722 · FACSIMILE (909)591-2198

www.yoshimura-rd.com

FENDER ELIMINATOR KIT

070BG133201
Yamaha R3

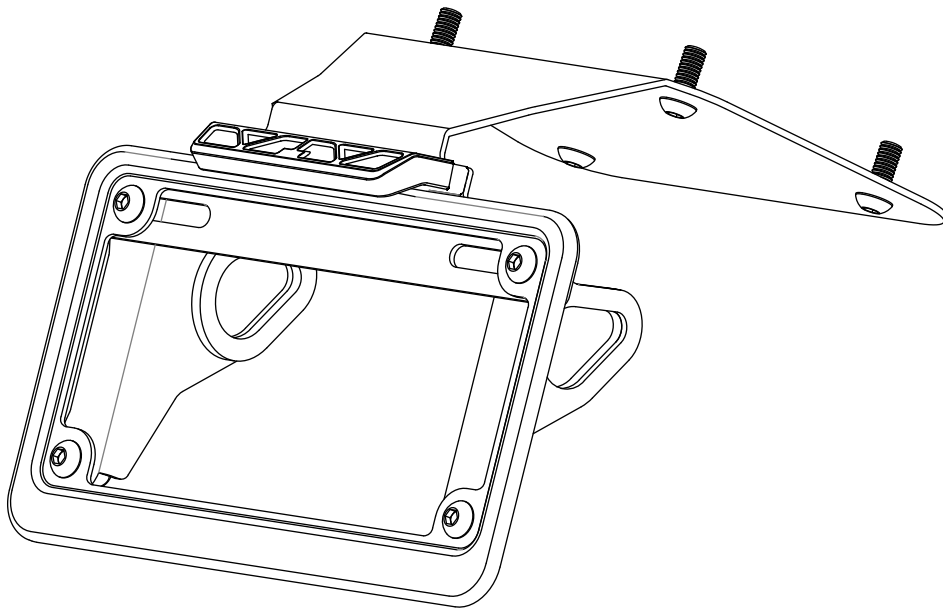

THIS PRODUCT IS NOT DOT APPROVED.

Yoshimura R&D of America, Inc. is not liable or responsible for any resulting event caused by the installation of this product. Check with local laws and regulations for compliance prior to installation and use. This product is not intended for use on public highways.



Assembly Diagram

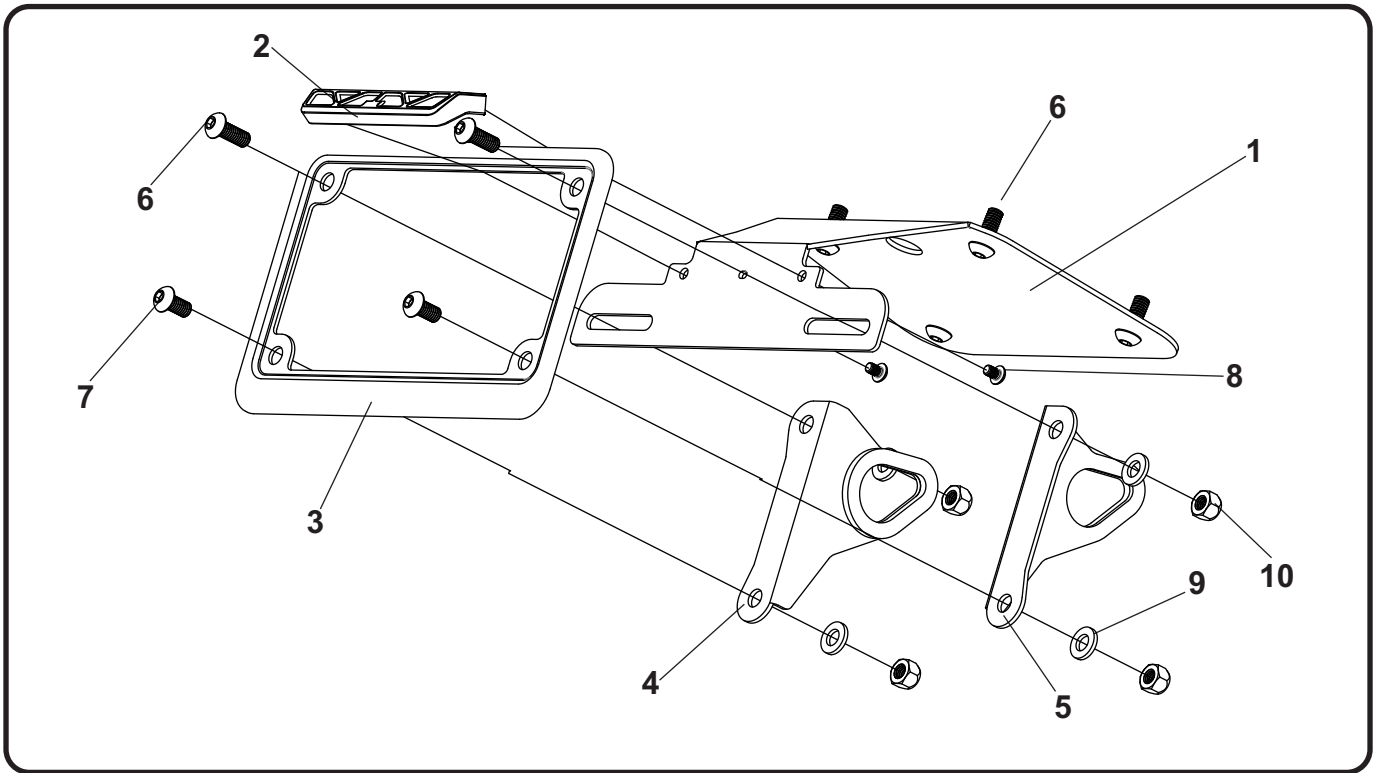

No.	Item	Description	Qty.
1	13320-FEBKT	Fender Eliminator Bracket	1
2	070BG-LH-K1	LED License Plate Light	1
3	070BG-LPF	License Plate Frame	1
4	13630-TSBL-00	Left Turn Signal Bracket	1
5	13630-TSBR-00	Right Turn Signal Bracket	1
6	M6X16BHS	6mm x 16mm Button Head Screw	6
7	M6X14BHS	6mm x 14mm Button Head Screw	2
8	M4X6BHS	4mm x 6mm Button Head Screw	2
9	6MMWASHER	6mm Washer	4
10	6MMLN	6mm Nylon Lock Nut	4
**	BN-SSS-22-18	Butt Connectors	2
**	ZT-300	Cable Ties	3
**	17029	Yoshimura Sticker Sheet	1
Optional Parts			
***	070BGUNVTBKT	Universal Turn Signal Bracket Kit	

*** The Yoshimura Universal Turn Signal Bracket Kit is to be used with aftermarket stud-mounted turn signals and is sold separately.

Removal

1. Remove passenger and rider seat.
2. Remove the two screws securing the plastic tray and remove.
3. Locate and disconnect license plate light and turn signal wires.
4. While securely supporting the stock fender assembly, remove the four nuts securing the fender assembly to frame. Carefully remove the stock fender assembly making sure not damage the license plate light and turn signal connectors.
5. Disassemble the stock fender assembly and remove left and right turn signals.
6. Cut the stock license plate light connector from the stock fender assembly. Be sure to cut at least a 6" section of wire from the connector.

Installation

1. Install (No. 2) *070BG-LH-K1*, Yoshimura license plate light onto (No. 1) *13320-FEBKT*, Yoshimura fender eliminator bracket using (No. 8) *M4X6BHS*, 4mm button head screws provided in the kit.

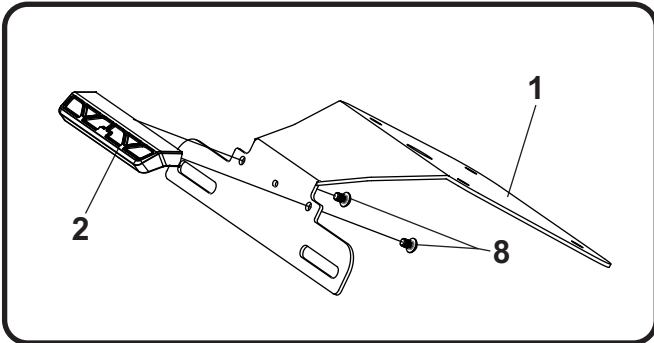

2. Secure (No. 1) *13320-FEBKT*, fender eliminator bracket to frame using (No. 6) *M6X16BHS*, bolts and the stock nuts.

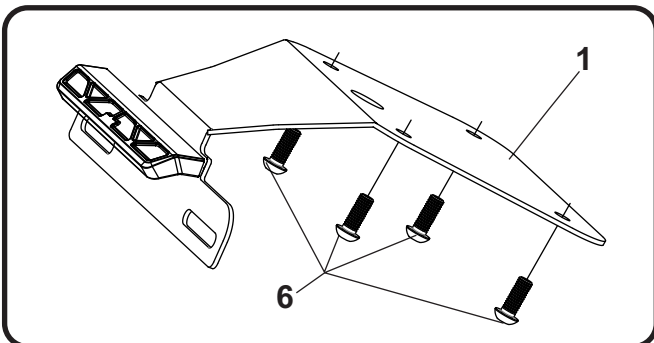

3. Using the *BN-SSS-22-18*, butt connectors provided in the kit, connect Yoshimura license plate light wires to the stock license plate light wires as follows:

Red -to- Blue
Black -to- Black

- a) Strip the stock fender light wire ends 1/4" - 1/2" and insert into *BN-SSS-22-18*, butt connectors provided in the kit.
- b) Center the spliced wire ends in the middle and using a heatgun or lighter, apply heat evenly on the outer edges of the butt connector to shrink and hold wires in place.
- c) Making sure that the stripped ends are centered, heat the center of the butt connector evenly until the solder begins to liquify.
- d) Allow to cool completely and tug both ends of the wires to verify that connection is secured.

Scan for link to butt connector instruction video



4. Install the stock left and right turn signals onto (No. 4,5) *13630-TSBL/R-00*, turn signal brackets using the stock hardware.
5. Install (No. 4,5) *13630-TSBL/R-00*, turn signal brackets and (No. 3) *070BG-LPF*, license plate frame using the (No. 6,7) *M6X16BHS* and *M6X12BHS*, 6mm button head screws as shown in the diagram.
6. Route license plate light and turn signal wires under passenger seat and reconnect.
7. Re-install the plastic tray.
8. Re-install rider and passenger seat.
9. Check for proper function of license plate light, turn signals, brake light, and that all brackets and components are secure prior to riding.