



# YOSHIMURA

RESEARCH&DEVELOPMENT OF AMERICA, INC.

5420 DANIELS STREET STE A, CHINO CA., 91710 · (800)634-9166 · (909)628-4722 · FACSIMILE (909)591-2198

[www.yoshimura-rd.com](http://www.yoshimura-rd.com)

## **FENDER ELIMINATOR KIT**

**070BG141821**  
**Kawasaki ZX10R**

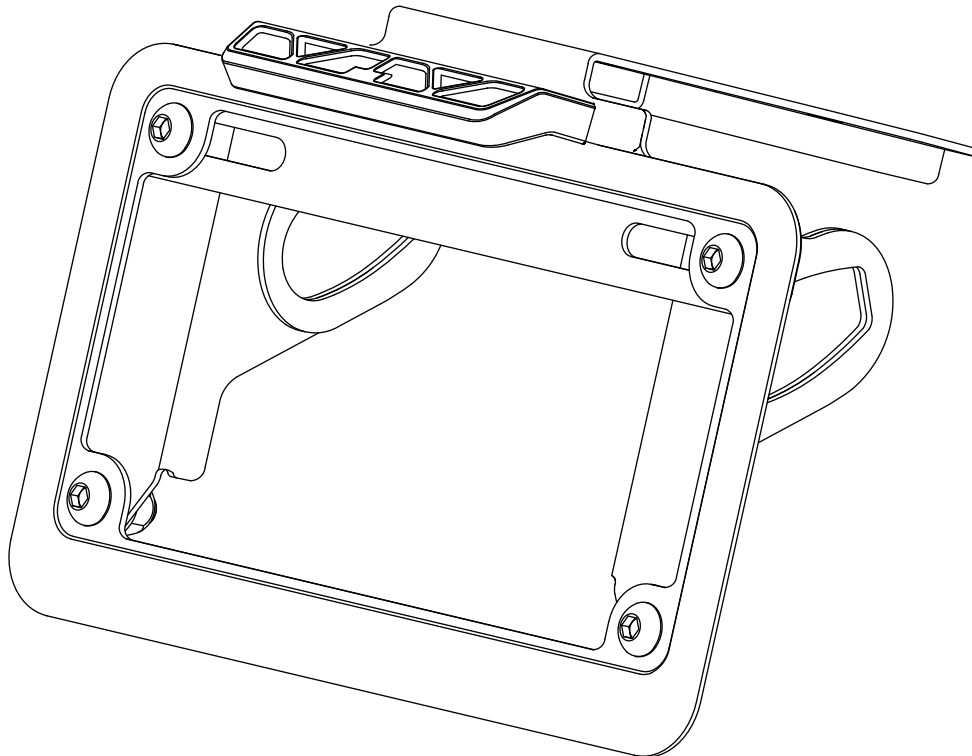

THIS PRODUCT IS NOT DOT APPROVED.  
Yoshimura R&D of America, Inc. is not liable or responsible for any resulting event caused by the installation of this product. Check with local laws and regulations for compliance prior to installation and use. This product is not intended for use on public highways.



## Assembly Diagram

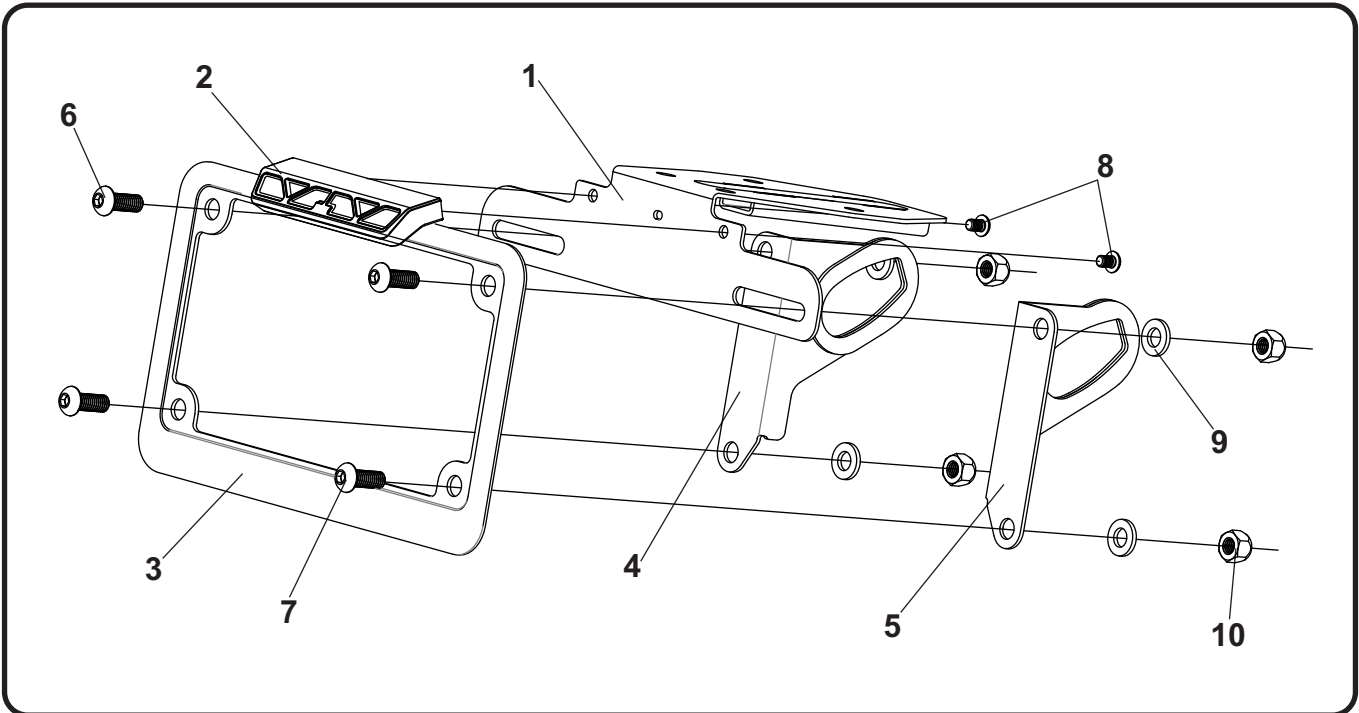

No.	Item	Description	Qty.
1	14182-FEBKT	Fender Eliminator Bracket	1
2	070BG-LH-K1	LED License Plate Light	1
3	070BG-LPF	License Plate Frame	1
4	14200-TSL	Left Turn Signal Bracket	1
5	14200-TSR	Right Turn Signal Bracket	1
6	M6X16BHS	6mm x 16mm Button Head Screw	2
7	M6X14BHS	6mm x 14mm Button Head Screw	2
8	M4X6BHS	4mm x 6mm Button Head Screw	2
9	6MMWASHER	6mm Washer	4
10	6MMLN	6mm Nylon Lock Nut	4
**	BN-SSS-22-18	Butt Connectors	2
**	ZT-400	Cable Ties	2
**	17029	Yoshimura Sticker Sheet	1
<b>Optional Parts</b>			
***	070BGUNVTBKT	Universal Turn Signal Bracket Kit	

\*\* Not shown on diagram.

\*\*\* The Yoshimura Universal Turn Signal Bracket Kit is to be used with aftermarket stud-mounted turn signals and is sold separately.

## Removal

1. Remove passenger seat.
2. Remove upper passenger seat cowl.
3. While securely supporting the stock fender assembly, remove the four bolts securing the fender assembly to the subframe. Carefully lower tail section to access license plate light and turn signal connectors.
4. Locate and disconnect license plate light and turn signal connectors and carefully remove the stock fender assembly making sure not to damage connectors in the process.
5. Disassemble the stock fender assembly and remove left and right turn signals from fender.
6. Cut the stock license plate light connector from the stock fender assembly. Be sure to cut at least a 6" section of wire from the connector.

## Installation

1. Install (No. 2) *070BG-LH-K1*, license plate light onto (No. 1) *14182-FEBKT*, fender eliminator bracket using (No. 8) *M4X6BHS*, 4mm screws.

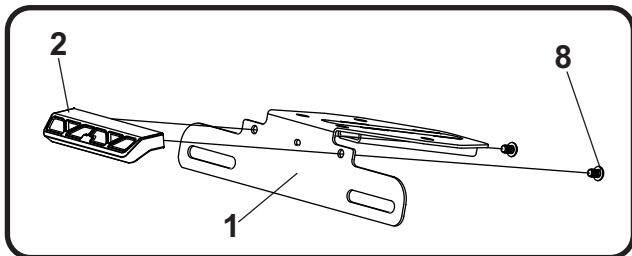

2. Using the *BN-SSS-22-18* butt connectors provided in the kit, connect the Yoshimura license plate light wires to the stock license plate light wires as follows:

Red -to- Red  
Black -to- Black with Yellow Stripe

- a) Strip the stock fender light wire ends 1/4" - 1/2" and insert into *BN-SSS-22-18*, butt connectors provided in the kit.
- b) Center the spliced wire ends in the middle and using a heatgun or lighter, apply heat evenly on the outer edges of the butt connector to shrink and hold wires in place.

- c) Making sure that the stripped ends are centered, heat the center of the butt connector evenly until the solder begins to liquify.
- d) Allow to cool completely and tug both ends of the wires to verify that connection is secured.

Scan for link to butt connector instruction video.



3. Install stock rear turn signals onto (No. 4,5) *14200-TSL/R*, left and right turn signal brackets.
4. Install (No. 4,5) *14200-TSL/R*, left and right turn signal brackets and (No. 3) *070BG-LPF*, license plate frame to (No. 1) *14182-FEBKT*, fender eliminator bracket using the (No. 6,7) *M6X16BHS* and *M6X14BHS*, 6mm button head screws and (No. 9,10) *6MMWASHER*, *6MMLN*, washer and nut as shown.

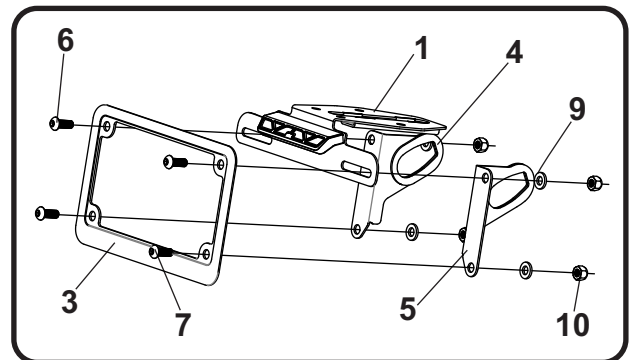

5. Route license plate light and turn signal wires through (No. 1) *14182-FEBKT*, fender eliminator bracket and through the lower rear cowl. Re-connect license plate light and turn signal connectors.
6. Using the four stock fender bolts, secure (No. 1) *14182-FEBKT*, fender eliminator to subframe. Torque to factory specification.

Note: Make sure license plate light and turn signal wires are not pinched between the lower tail and fender eliminator bracket. Wires should fit inside the channel of the fender eliminator bracket.

7. Use the cable ties supplied in the kit to secure license plate light and turn signal wires.

8. Re-install the rear upper passenger seat cowl and re-install passenger seat.
9. Check for proper function of license plate light and turn signals and that all brackets and components are secure prior to riding.