



# YOSHIMURA

RESEARCH&DEVELOPMENT OF AMERICA, INC.

5420 DANIELS STREET STE A, CHINO CA., 91710 · (800)634-9166 · (909)628-4722 · FACSIMILE (909)591-2198

[www.yoshimura-rd.com](http://www.yoshimura-rd.com)

## **FENDER ELIMINATOR KIT**

**070BG163900**  
**KTM RC390**

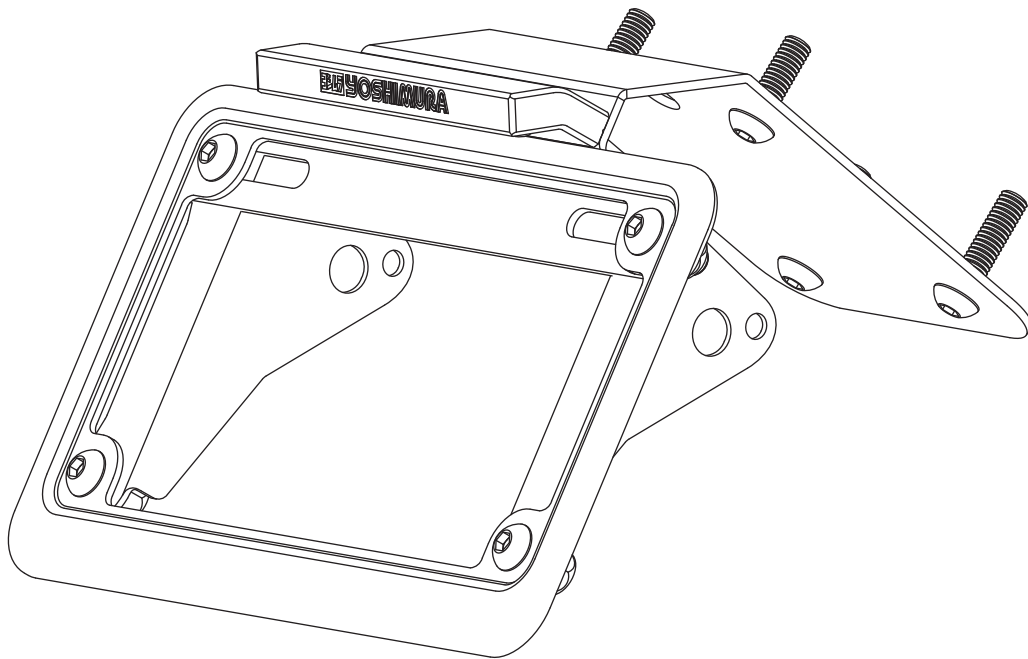

This product is not compatible with the Yoshimura high-mount exhaust system.



**THIS PRODUCT IS NOT DOT APPROVED.**

Yoshimura R&D of America, Inc. is not liable or responsible for any resulting event caused by the installation of this product. Check with local laws and regulations for compliance prior to installation and use. This product is not intended for use on public highways.



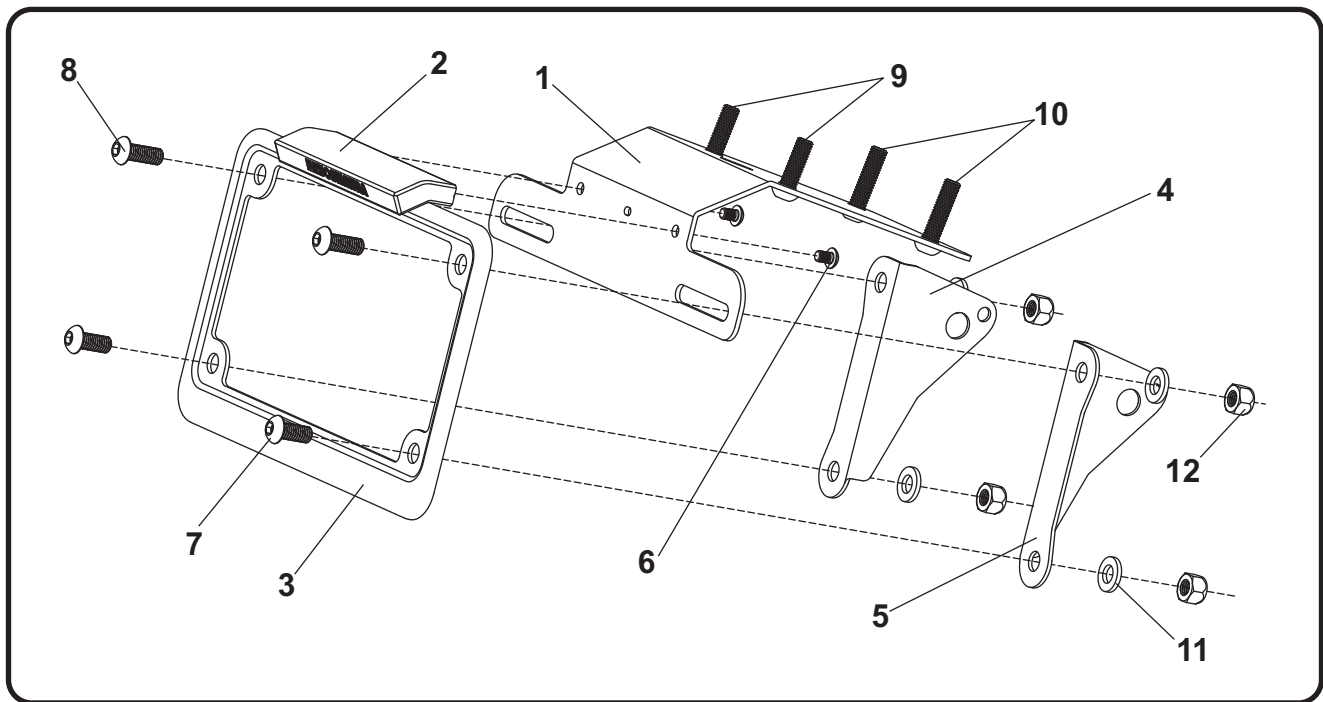

No.	Item	Description	Qty.
1	16390-FEBKT	Fender Eliminator Bracket	1
2	070BG-LH-K	LED License Plate Light	1
3	070BG-LPF	License Plate Frame	1
4	16390-TSL	Left Turn Signal Bracket	1
5	16390-TSR	Right Turn Signal Bracket	1
6	M4X6BHS	4mm x 6mm Button Head Screw	2
7	M6X14BHS	6mm x 14mm Button Head Screw	2
8	M6X16BHS	6mm x 16mm Button Head Screw	2
9	M6X20BHS	6mm x 20mm Button Head Screw	2
10	M6X25BHS	6mm x 25mm Button Head Screw	2
11	6MMWASHER	6mm Flat Washer	4
12	6MMLN	6mm Nylon Lock Nut	4
**	94785-01-ND	Butt Connectors	2
**	ZT-300	Cable Ties	3
**	HST-.25-.08-3	Heat Shrink Tube	1
**	17029	Yoshimura Sticker Sheet	1
<b>Optional Parts</b>			
***	070BGUNVTBKT	Universal Turn Signal Bracket Kit	

\*\* Not shown on diagram.

\*\*\* The Yoshimura Universal Turn Signal Bracket Kit is to be used with aftermarket stud-mounted turn signals and is sold separately.

## Removal

1. Remove rider seat.
2. Remove passenger seat bolt and slide passenger seat forward to remove.
3. Locate and disconnect license plate light and turn signal connectors.
4. While supporting the stock fender assembly, remove the four nuts securing the fender assembly to the frame. Carefully remove the stock fender assembly making sure not to damage connectors during removal.
5. Disassemble stock fender assembly and remove left and right turn signals.
6. Cut the stock license plate light connector from the stock fender assembly. Be sure to cut at least a 6" section of wire from the connector.

## Installation

1. Install stock left and right turn signals onto (No. 4,5) *16390-TSL/R*, left and right turn signal brackets.
2. Install (No. 2) *070BG-LH-K*, Yoshimura license plate light onto (No. 1) *16390-FEBKT*, Yoshimura fender eliminator bracket using (No. 6) *M4X6BHS*, 4mm button head screws provided in the kit.

Note: Slide supplied heat shrink tube over license plate light wires at this time. Keep away from potential heat sources.

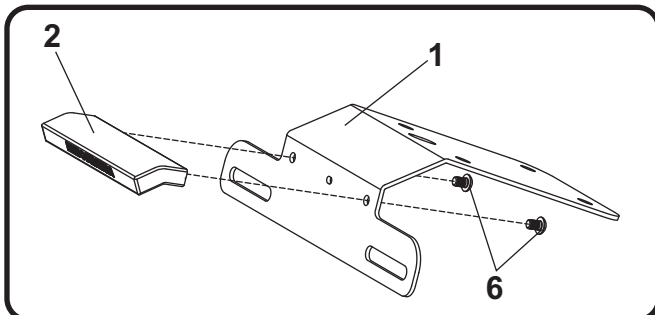

3. Assemble Yoshimura fender eliminator by installing (No. 4,5) *16390-TSL/R*, left and right turn signal brackets and (No. 3) *070BG-LPF*, license plate frame using the (No. 7,8) *M6X14BHS* and *M6X16BHS*, 6mm button head screws as shown.

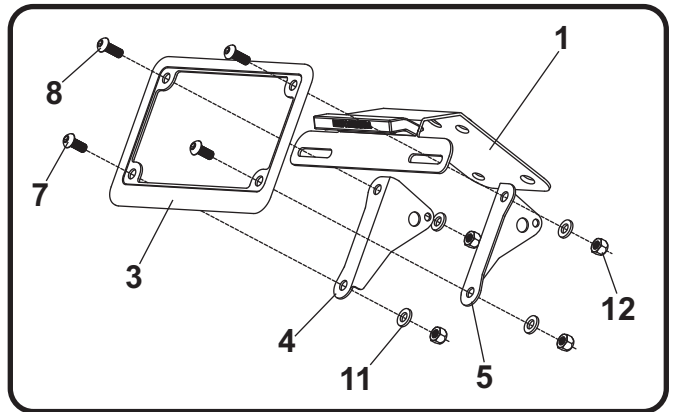

4. Route license plate light wire through the hole in bracket and under passenger seat. Using the *94785-01-ND* butt connectors provided in the kit, connect the Yoshimura license plate light wires to the stock license plate light wires as follows:

Black w/ Yellow Stripe -to- Red  
Brown -to- Black

Note: The butt connectors must be offset when splicing into license plate light wires to allow enough room to slide shrink tube over both butt connectors.

### CORRECT



### INCORRECT

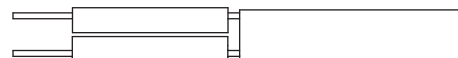

5. Route turn signal wires under passenger seat and re-connect. Re-connect license plate light connector.
6. Install (No. 1) *16390-FEBKT*, assembled fender eliminator to frame using the stock nuts and (No. 9,10) *M6X20BHS* and *M6X25BHS*, 6mm screws as shown below. Torque to factory specification.

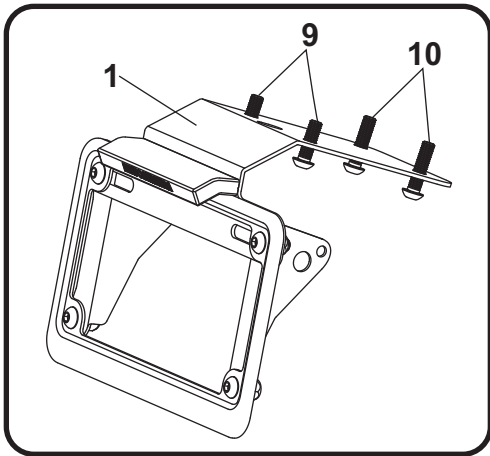

7. Use the cable ties provided in the kit to secure license plate light and turn signal wires beneath passenger seat.
8. Re-install passenger and rider seat.
9. Check for proper function of license plate light and turn signals and that all brackets and components are secure prior to riding.