



YOSHIMURA

RESEARCH&DEVELOPMENT OF AMERICA, INC.

5420 DANIELS STREET STE A, CHINO CA., 91710 · (800) 634-9166 · (909) 628-4722 · FAX (909) 591-2198

www.yoshimura-rd.com

Signature Series

Qualified Manufacturer Declared "Replacement Part"

2016~2019

SUZUKI GSX-S1000(F)

11100EM220 (CF/CF)

11100EM520 (SS/CF)

Alpha Stainless Steel Slip-On



Signature Series systems are:

- CARB/EPA tail-pipe emissions compliant.
- Marked with appropriate EPA noise labels.
- Independent laboratory tested for EPA new vehicle noise compliance.



✘ You must know how to remove and replace your stock exhaust in order to install this product otherwise have it installed by a professional mechanic. Keep all stock parts from your existing system as some components may be necessary to install your new Yoshimura exhaust depending on the application. Read through all instructions before beginning installation. Exhaust system can be extremely hot. Let motorcycle cool down before beginning installation. Always wear hand and eye protection and take precautionary measures to avoid injury. ✘

NOTE: IN THE STATE OF CALIFORNIA, IT IS ILLEGAL TO MODIFY THE EMISSION CONTROL SYSTEM, WHICH INCLUDES THE CARBURETORS OF ANY VEHICLE.

Assembly Diagram

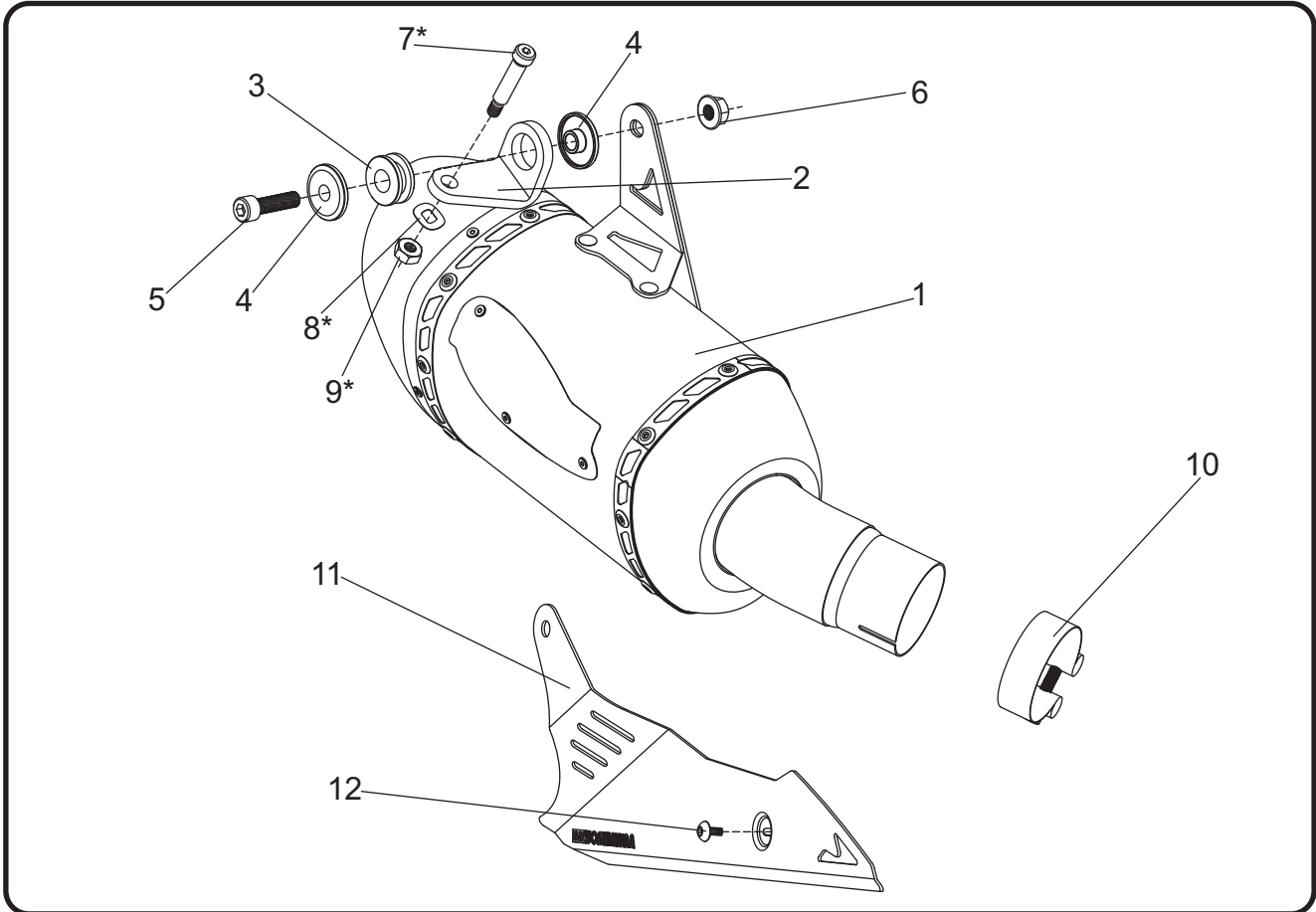

No.	Item	Description	Qty.
1	****	Signature Series Muffler	1
2	11100-BRKT	Muffler Mount Bracket	1
3	Z1023	Rubber Grommet	1
4	ALS-043	Aluminum Spacer	2
5	M8X30	8mm x 30mm Socket Head Cap Screw	1
6	8MMNUT	8mm Flange Nut	1
7*	S5/16X1.25X0.25	1/4 in. -20 TPI Shoulder Bolt	1
8*	S0.25WASHER-WV	Wave Washer	1
9*	S0.25LOCKNUT	1/4 in. -20 TPI Expanding Locknut	1
10	03019143	Exhaust Clamp	1
11	11100-435-HS	Heatshield	1
12	RC116HSB-BK	Heatshield Screw	1
**	R-K880ND	Thread Lock	1
**	17100	Sticker Sheet	1

* Standard Size. (NOT METRIC)

** Not shown on diagram.

**** Signature Series muffler replacement part number unavailable. Repair or replacement of Signature Series exhaust systems is only available directly through Yoshimura R&D of America, Inc.

Removal

1. Remove the stock muffler heatshield by removing the heatshield bolt.
2. Loosen the exhaust clamp between the muffler and header.
3. While securely supporting the stock muffler, remove the muffler mount bolt and carefully remove the stock muffler assembly.

Note¹: The stock exhaust gasket will be re-used with the Yoshimura system. Inspect and replace if necessary.

Note²: Due to limited space between the muffler and swingarm, it is recommended to mask swingarm with tape or a soft cloth to prevent scratching during removal and installation of the muffler.

4. Remove right passenger footpeg cotter-pin and remove the footpeg securing pin.

Note: To prevent loss of small footpeg assembly components, do not disassemble or remove the footpeg from bracket.

Installation

1. Install (No. 3) Z1023, rubber grommet into (No. 2) 11100-BRKT, muffler mount bracket.

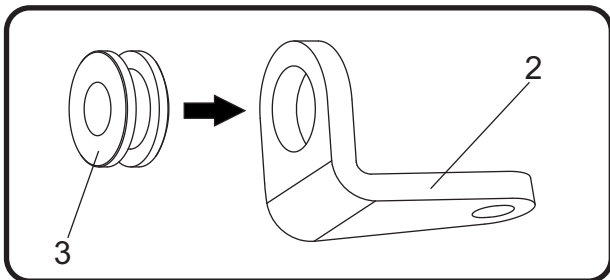

2. Install (No. 4) ALS-043, aluminum spacer into (No. 3) Z1023, rubber grommet as shown.

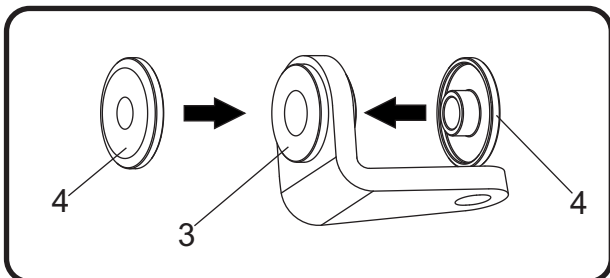

3. Install (No. 2) 11100-BRKT, muffler mount bracket to muffler using (No. 5) M8X30, bolt and (No. 6) 8MMNUT, flange nut as shown. Do not torque at this time as adjustability is required for proper alignment in Step 6.

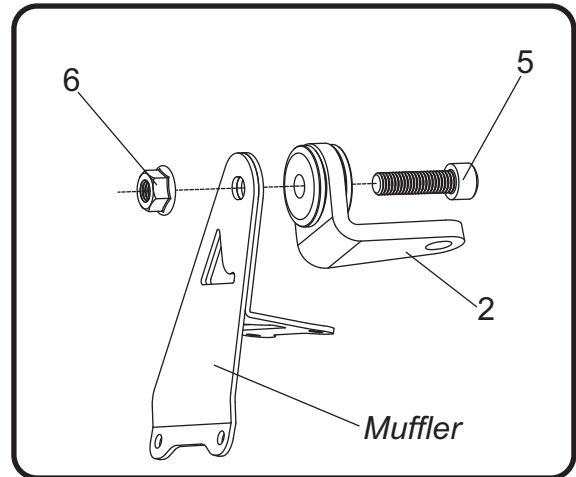

4. Install (No. 10) 27-63M, exhaust clamp over tailpipe.
5. Install tailpipe over the stock header outlet and align (No. 2) 11100-BRKT, muffler mount bracket to the bottom of the right passenger footpeg bracket. Secure using (No. 7) S5/16X1.25X0.25, shoulder bolt, (No. 8) S0.25WASHER-WV, wave washer and (No. 9) S0.25LOCKNUT, expanding locknut. Do not torque at this time.

Note: Make sure that the top of the muffler mount bracket is parallel to the bottom of the footpeg bracket.

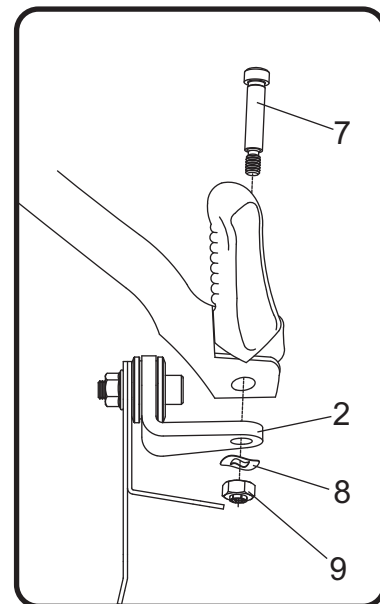

6. Standing at the back of the motorcycle, check and adjust muffler and bracket until desired alignment is achieved. Using a marker, mark (No. 2) *11100-BRKT*, muffler mount bracket and (No. 1) *muffler* bracket.

Note: In order to torque (No. 5) *M8X30*, bolt (No. 2) muffler mount bracket must be separated from the passenger footpeg bracket.

7. Remove (No. 7) *S5/16X1.25X0.25*, shoulder bolt and remove (No. 2) *11100-BRKT*, muffler mount bracket from the passenger footpeg.
8. Making sure that the marks made previously on the muffler bracket and muffler mount bracket are still aligned, torque (No. 5) *M8X30*, bolt to 23 Nm (2.3 kg-m, 17 ft-lb).

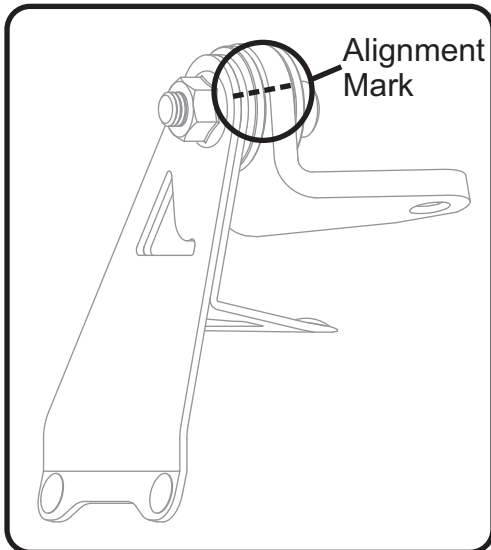

9. Repeat Step 5 and secure (No. 2) *11100-BRKT*, muffler mount bracket to the right passenger footpeg bracket. Apply thread lock onto shoulder bolt threads.

Note¹: Tighten shoulder bolt until the wave washer becomes flat on the bottom surface of the muffler mount bracket.

Note²: Do not over-tighten shoulder bolt. The bolt is installed at a slight angle and may bend or warp if over-tightened.

10. Torque (No. 10) *27-63M*, exhaust clamp to 8.5 Nm (0.85 kg-m, 6 ft-lb).
11. Install (No. 11) *11100-435-HS*, heatshield using (No. 12) *RC116HSB-BK*, heatshield screw and the stock muffler mount bolt.

12. Before starting vehicle, check for proper clearance between new exhaust system and rear suspension (i.e. tire, swingarm, brakes, rear shock, and etc.) If any problem is found, please carefully follow through the installation steps again. If problem still persists, please call Yoshimura Tech Department at (800) 634-9166 / in CA (909) 628-4722.

13. It is recommended that the muffler and tailpipe be wiped down with rubbing alcohol to remove oil and fingerprints. This will help prevent tarnishing of the finish after the exhaust is heated up.

Note: After starting motorcycle, it is normal for new exhaust system and muffler to emit smoke until oil residue burns off.

NOISE EMISSION WARRANTY

Yoshimura warrants that this exhaust system, at time of sale, meets all applicable U.S. E.P.A. Federal noise standards. This warranty extends to the first person who buys this exhaust system for purposes other than resale, and to all subsequent buyers. Warranty claims should be directed to Yoshimura R&D of America, Inc. 5420 Daniels St. Chino, CA 91710 | Tel (800) 634-9166

TAMPERING PROHIBITION

Federal law prohibits any modification to this exhaust system which causes the motorcycle to exceed the Federal noise standard. Use of the motorcycle with such a modified exhaust system is also prohibited.

Acts likely to constitute tampering include removal or puncturing the muffler, baffles, header pipes, or any other component which conducts exhaust gases.

WARNING: This product should be checked for repair or replacement if the motorcycle noise has increased significantly through use. Otherwise, the owner may become subject to penalties under state and local ordinances.