



RACE SERIES

Qualified Manufacturer Declared "Modified Part"

APPLICATION

YEAR	MODEL
2013	Honda CB1100

PRODUCT

121108K500	Imported Yoshimura Japan Steel Hand Bent RSCV Full-System Exhaust
121100K500	Yoshimura RSCV Stainless Steel Full-System Exhaust

FOR CLOSED COURSE COMPETITION ONLY; NOT INTENDED FOR STREET USE

	<i>This product is designed for use in closed course racing and is not intended for highway use. In the state of California, it is illegal to modify the emission control system, which includes the fuel injection of any vehicle.</i>
	<i>You must know how to remove and replace your stock exhaust in order to install this product otherwise have it installed by a professional mechanic. Keep all stock parts from your existing system as some components may be necessary to install your new Yoshimura exhaust depending on the application.</i>
	<i>Read through all instructions before beginning installation. Exhaust system can be extremely hot. Let motorcycle cool down before beginning installation. Always wear hand and eye protection and take precautionary measures to avoid injury.</i>

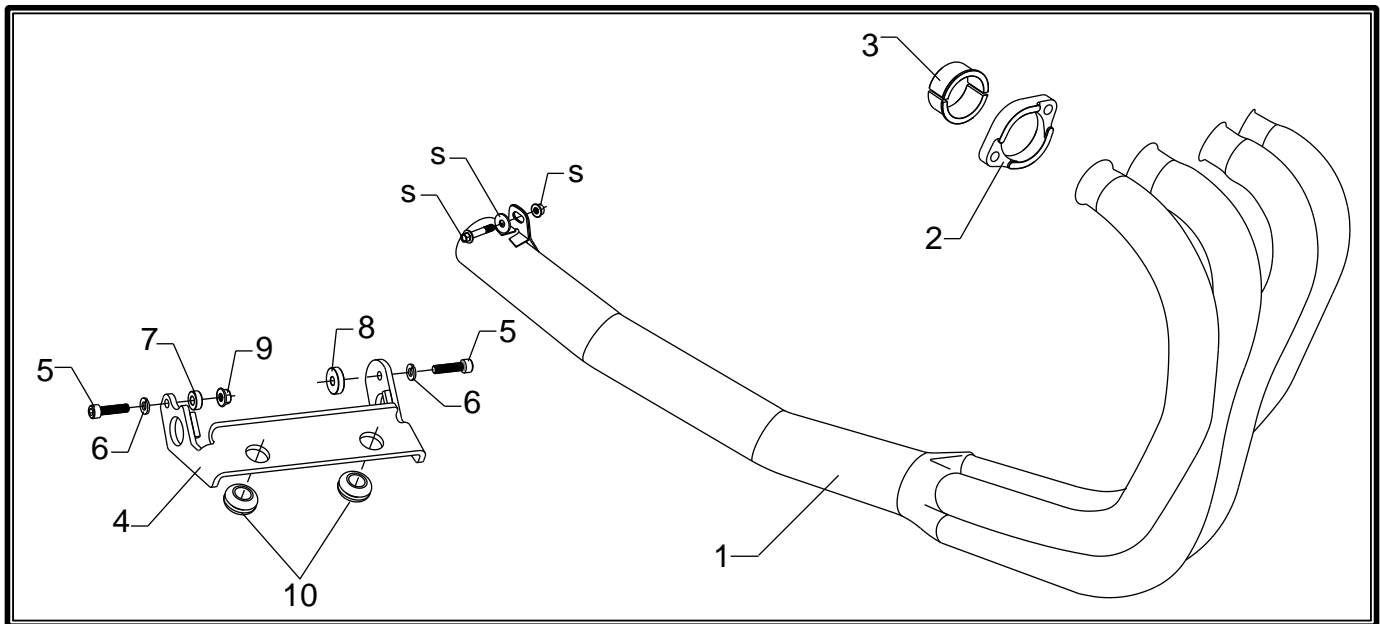

No.	Part #	Description	Qty
1	12110-401HB 12110-401	Yoshimura Steel Hand Bent Full-System Yoshimura Stainless Steel Full-System	1
2	12110ADR	Yoshimura Flange	4
3	12110SDM	Yoshimura Manifold	4
4	12110-SSTP	Center Stand Bracket	1
5	M6X25	6mm x 25mm Socket Head Cap Screw	2
6	6X10LW	6mm Split Lock Washer	2
7	6X14X5SPCR	Small Aluminum Spacer	1
8	6X20X5SPCR	Large Aluminum Spacer	1
9	6MMNUT	6mm Nut	1
10	Z1022	Rubber Grommet	2
**	ZT-300	Cable Ties	2
**	17029	Yoshimura Sticker Sheet	1

-TOOLS REQUIRED-

Metric Socket Set • Combination Wrench Set • Torque Wrench • Metric Allen Wrench Set
Electrical Tape • Duct Tape • Rubber Band • Shop Rags

ⓘ IMPORTANT ⓘ

WRAP FRAME NEAR HEADER WITH SHOP RAGS AND/OR DUCT TAPE TO PREVENT SCRATCHING THE FRAME WHEN REMOVING AND INSTALLING THE HEADER.

ASSISTANCE FROM ANOTHER PERSON IS RECOMMENDED WHEN REMOVING AND INSTALLING THE EXHAUST SYSTEM.

-REMOVAL-

1. Remove the muffler heatshield bolt and remove the stock heatshield by sliding toward the front of the bike.
2. Loosen stock exhaust clamp at header and muffler connection.
3. While securely supporting the stock muffler assembly remove the muffler mount bolt.
4. Slide the stock muffler off of header by sliding toward the rear of the bike.
5. Remove stock O2 sensor from the stock header.
6. Remove chassis mount bolt securing header to frame.
7. If you have not done so already, wrap the frame near the header with a rag and/or tape before removing header. While securely supporting the stock header, remove the header nuts and carefully remove header.

Note: Removal of front wheel and front fender will ease installation. Check with Factory Service or Owners manual for proper removal procedure.

-INSTALLATION-

1. Install rubber grommets onto Yoshimura center stand bracket.
2. Install Yoshimura center stand bracket to stock frame using the hardware provided in the kit. See diagram below for proper orientation and order of hardware.

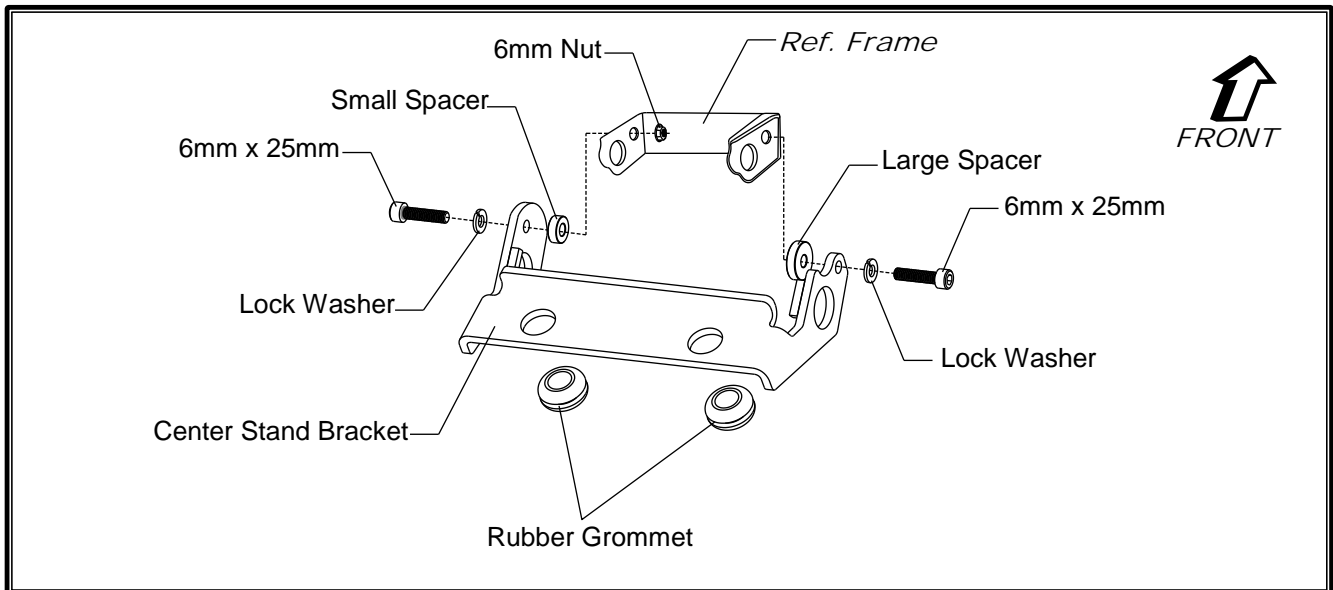

3. Tie rubber bands onto each header leg near the inlet and slide flange over header as shown below. Note: The purpose of the rubber band is to prevent the flange from sliding down the header and scratching the header coating. Rubber band will be removed later.

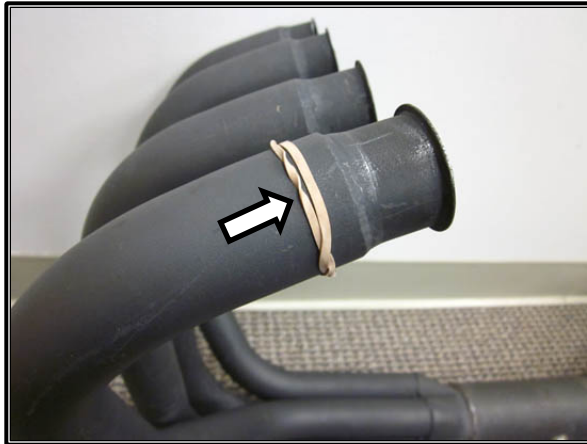

4. Slide flange over header.
5. Place the two halves of the manifold onto header inlet. Using tape, wrap the two halves of the manifold to secure them together. Fold over the tape at the end to create a tab. This will ease removal of the tape after header is installed. See below for diagram and orientation of the flange and manifold.

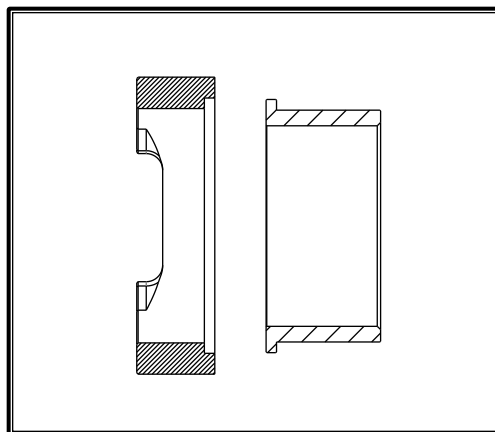
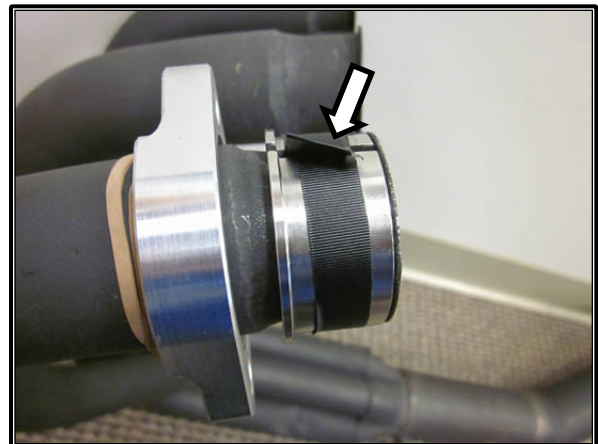
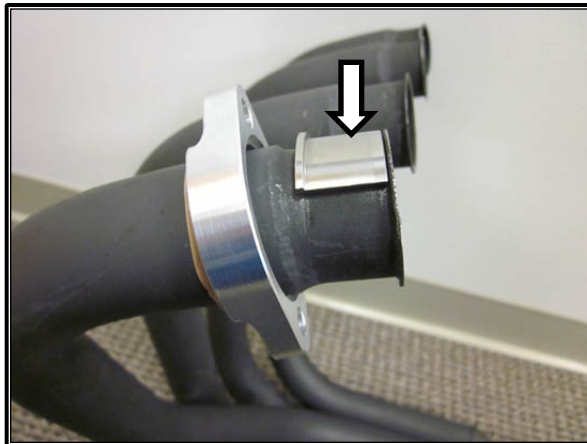

6. **Install Yoshimura exhaust system by carefully maneuvering around the frame. Carefully insert each header leg into exhaust port and secure using the stock header nuts. Do not torque at this time. See diagram for proper flange orientation.**

Note¹: The stock exhaust port gaskets will be reused with the Yoshimura exhaust system. Inspect and replace if necessary.

Note²: Header legs will not directly slide into exhaust port due to the outer legs having a slight angle to them. Install from one side to the other. There is slight flex in the header legs to allow for tolerance.

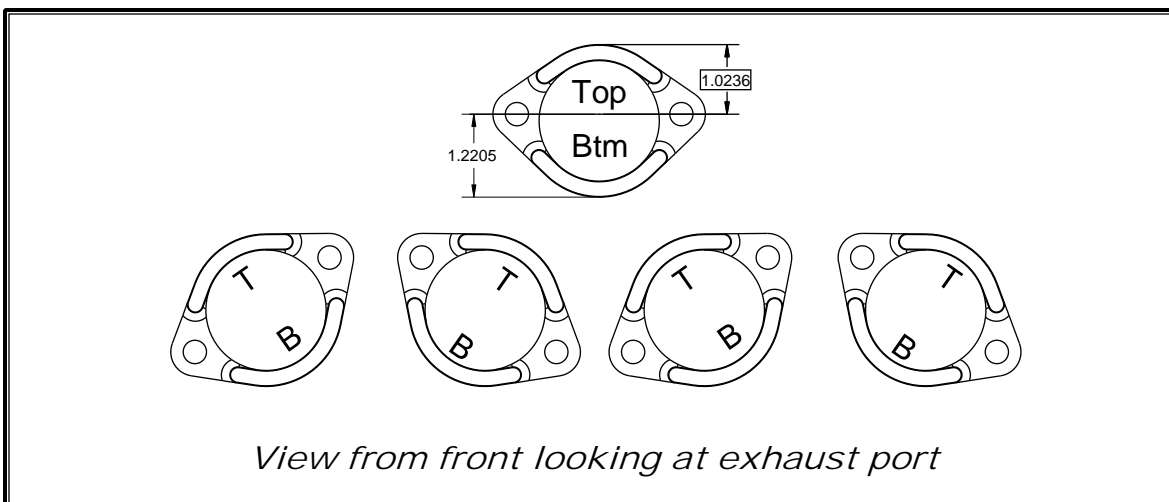

7. **Cut rubber band off of header legs.**
8. **Carefully remove tape securing the two halves of the manifold together by pulling on the tab created at the end of the tape.**
9. **Secure muffler to inside of muffler mount using the stock bolt, washer, and nut. Do not torque at this time.**

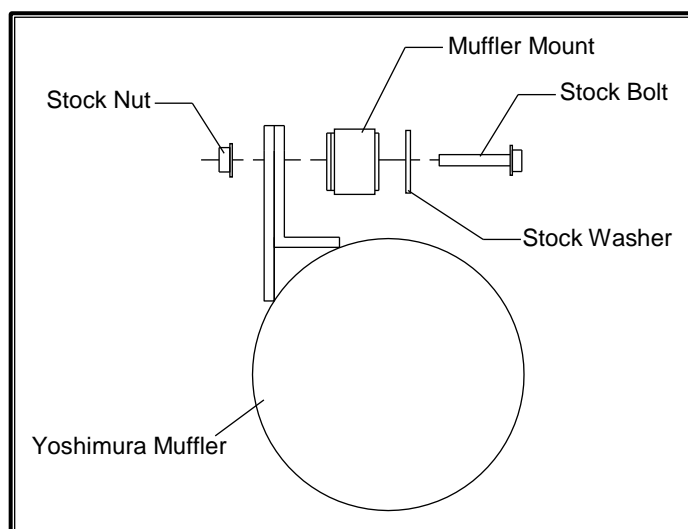

10. **Re-install stock O2 sensor onto Yoshimura exhaust system. Torque to factory specification.**
11. **Torque muffler mount bolt to factory specification.**
12. **Make sure header legs are fully seated in exhaust port and torque header nuts to factory specification.**

13. Using the provided cable ties, secure O2 sensor wire to oil sensor wire away from the header. Be sure there is sufficient clearance to prevent O2 sensor wire from getting damaged by exhaust heat.



View from beneath left side

14. Before starting motorcycle, check for proper clearance between new exhaust system and rear suspension (i.e. tire, swing-arm, brake, rear shock, engine, and etc.) If any problem is found, please carefully follow through the installation steps again. If problem still persists, please call Yoshimura Tech Department at (800) 634-9166 / in CA (909) 628-4722.
15. It is recommended that the muffler and tailpipe be wiped down with rubbing alcohol to remove oil and fingerprints. This will help prevent tarnishing of the finish after the exhaust is heated up.
Note: After starting motorcycle, it is normal for new exhaust system and muffler to emit smoke until oil residue burns off.