



SIGNATURE SERIES

Qualified Manufacturer Declared "Replacement Part"

APPLICATION

YEAR	MODEL
2013-2015	Honda CB500X Honda CB500F Honda CBR500R

PRODUCT

12500E0220	R77 SS Slip-On Exhaust with Carbon Fiber Sleeve; Carbon Fiber Endcap
12500E0520	R77 SS Slip-On Exhaust with Stainless Steel Sleeve; Carbon Fiber Endcap

	This product is 50-state legal and complies with Federal and State regulations. Any attempts to modify this product will render it non-compliant with Federal law and void warranty. If modified, the vehicle can no longer be used on public roads and can only be used for off-highway closed course competition. In the state of California, it is illegal to modify the emission control system, which includes the fuel injection system of any vehicle.
	You must know how to remove and replace your stock exhaust in order to install this product otherwise have it installed by a professional mechanic. Keep all stock parts from your existing system as some components may be necessary to install your new Yoshimura exhaust depending on the application.
	Read through all instructions before beginning installation. Exhaust system can be extremely hot. Let motorcycle cool down before beginning installation. Always wear hand and eye protection and take precautionary measures to avoid injury.

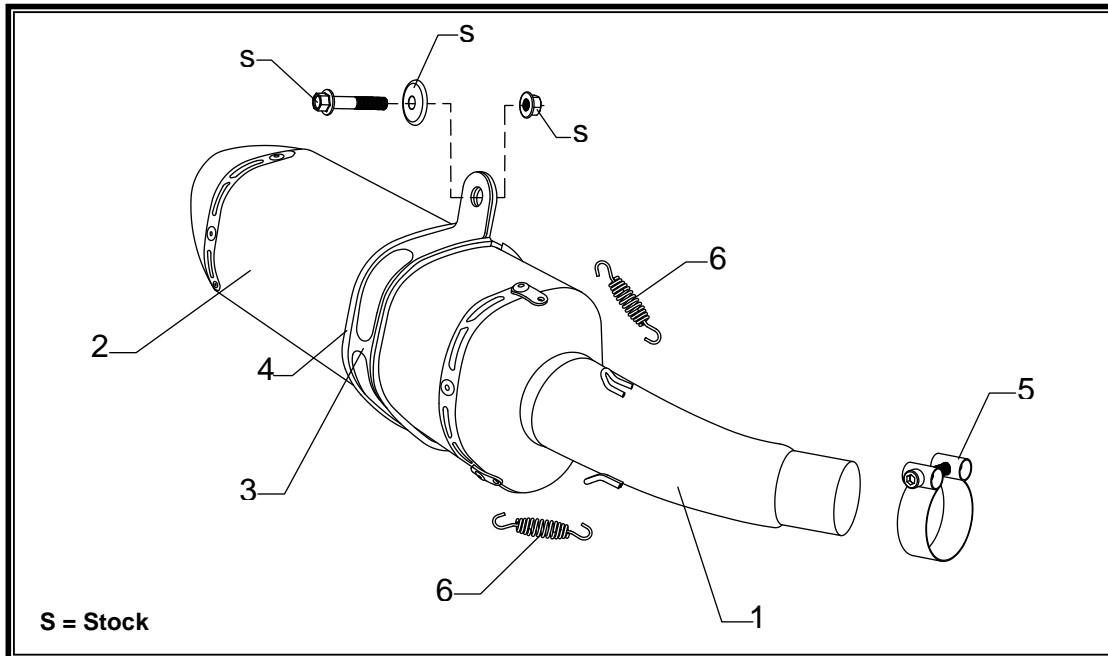

No.	Part #	Description	Qty
1	12560-435	Yoshimura Tailpipe	1
2	**	Yoshimura Muffler	1
	**	Carbon Fiber Sleeve; CF Endcap	
	**	Stainless Steel Sleeve; CF Endcap	
3	1121-MPCR 1121-MPCRX	Muffer Clamp Use with CF Sleeve Use with SS Sleeve	1
4	HT SHLDR77	Yoshimura Muffer Clamp Heatshield	1
5	27-59M	Exhaust Clamp	1
6	RACE-SPS-1	Medium Spring	2
**	S-RIVET	Securing Rivet	1
**	ST-200	Spring Puller Tool	1
**	17029	Yoshimura Sticker Sheet	1

-TOOLS REQUIRED-

*Metric Socket Set • Combination Wrench Set • Torque Wrench
Metric Allen Wrench Set • Power Drill • ¹³/₆₄" Drill Bit*

-REMOVAL-

1. **Loosen the stock exhaust clamp.**
2. **While securely supporting the muffler, remove muffler mount bolt and slide stock muffler toward the rear of the bike off of the stock header.**

NOTE: Stock exhaust gasket will not be used with the Yoshimura Slip-On exhaust system.

-INSTALLATION-

1. **Slide provided exhaust clamp over Yoshimura tailpipe.**
2. **Install rubber heatshield onto muffler clamp.**
3. **Slide clamp over Yoshimura muffler.**
4. **Slide Yoshimura muffler assembly over stock header outlet.**
5. **Align muffler clamp to stock muffler mount and install using stock bolt, stock washer, and stock nut.**

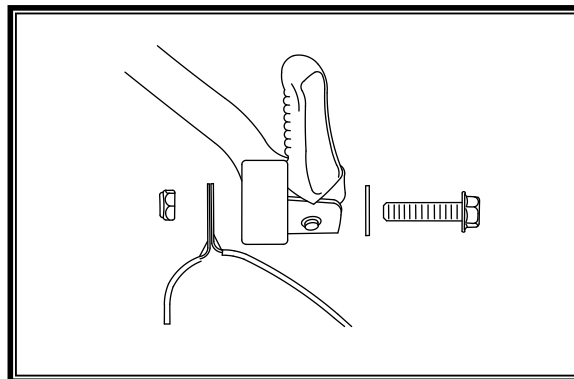

NOTE: Muffler clamp mounts to the inside of the muffler mount.

6. **Standing at the back of the motorcycle, check for proper alignment of the muffler. Adjust if necessary.**

NOTE¹: To adjust fitment, it may be necessary to rotate the tailpipe of the muffler independently until proper alignment of the muffler is achieved.

NOTE²: We will be installing a securing rivet in the tailpipe to prevent the tailpipe from rotating while the motorcycle is in operation.

7. **Torque muffler mount bolt to 17 ft-lb (23 Nm, 2.3 kg-m).**
8. **Drill a ¹³/₆₄" hole through the outlet of the stock header using the securing hole located near the Yoshimura tailpipe inlet as your guide.**

CAUTION: Always wear eye protection when using any power tools.

9. ***Insert securing rivet into drilled hole and slide exhaust clamp over rivet.***
10. ***Torque exhaust clamp to 10 ft-lb (13.5 Nm, 1.3 kg-m).***
11. ***Before starting motorcycle, check for proper clearance between new exhaust system and rear suspension (i.e. tire, swing-arm, brake, rear shock, engine, and etc.) If any problem is found, please carefully follow through the installation steps again. If problem still persists, please call Yoshimura Tech Department at (800) 634-9166 / in CA (909) 628-4722.***
12. ***It is recommended that the muffler and tailpipe be wiped down with rubbing alcohol to remove oil and fingerprints. This will help prevent tarnishing of the finish after the exhaust is heated up.***

NOTE: After starting motorcycle, it is normal for new exhaust system and muffler to emit smoke until oil residue burns off.

NOISE EMISSION WARRANTY

Yoshimura warrants that this exhaust system, at time of sale, meets all applicable U.S. E.P.A. Federal noise standards. This warranty extends to the first person who buys this exhaust system for purposes other than resale, and to all subsequent buyers. Warranty claims should be directed to Yoshimura R&D of America, Inc.
5420 Daniels St. Chino, CA 91710 | Tel (800) 634-9166

TAMPERING PROHIBITION

Federal law prohibits any modification to this exhaust system which causes the motorcycle to exceed the Federal noise standard. Use of the motorcycle with such a modified exhaust system is also prohibited.

Acts likely to constitute tampering include removal or puncturing the muffler, baffles, header pipes, or any other component which conducts exhaust gases.

WARNING: This product should be checked for repair or replacement if the motorcycle noise has increased significantly through use. Otherwise, the owner may become subject to penalties under state and local ordinances.