



# YOSHIMURA

RESEARCH&DEVELOPMENT OF AMERICA, INC.

5420 DANIELS STREET STE A, CHINO CA., 91710 · (800) 634-9166 · (909) 628-4722 · FAX (909) 591-2198

[www.yoshimura-rd.com](http://www.yoshimura-rd.com)

## RACE SERIES

Qualified Manufacturer Declared "Modified Part"

**Yamaha FZ-07**  
2015~2017

**Yamaha XSR700**  
2018~2020

**Yamaha MT-07**  
2018~2020

**137000J220 (CF/CF)**

**137000J520 (SS/CF)**

**R-77 Stainless Steel Full-System**

**FOR CLOSED COURSE COMPETITION ONLY; NOT INTENDED FOR STREET USE**

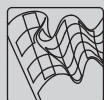

Race Series systems are:

- NOT CARB/EPA tail-pipe emissions compliant.
- NOT street legal.
- For "Closed Course Competition" use only.

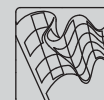

*You must know how to remove and replace your stock exhaust in order to install this product otherwise have it installed by a professional mechanic. Keep all stock parts from your existing system as some components may be necessary to install your new Yoshimura exhaust depending on the application. Read through all instructions before beginning installation. Exhaust system can be extremely hot. Let motorcycle cool down before beginning installation. Always wear hand and eye protection and take precautionary measures to avoid injury.*



NOTE: IN THE STATE OF CALIFORNIA, IT IS ILLEGAL TO MODIFY THE EMISSION CONTROL SYSTEM, WHICH INCLUDES THE CARBURETORS OF ANY VEHICLE.

## Assembly Diagram

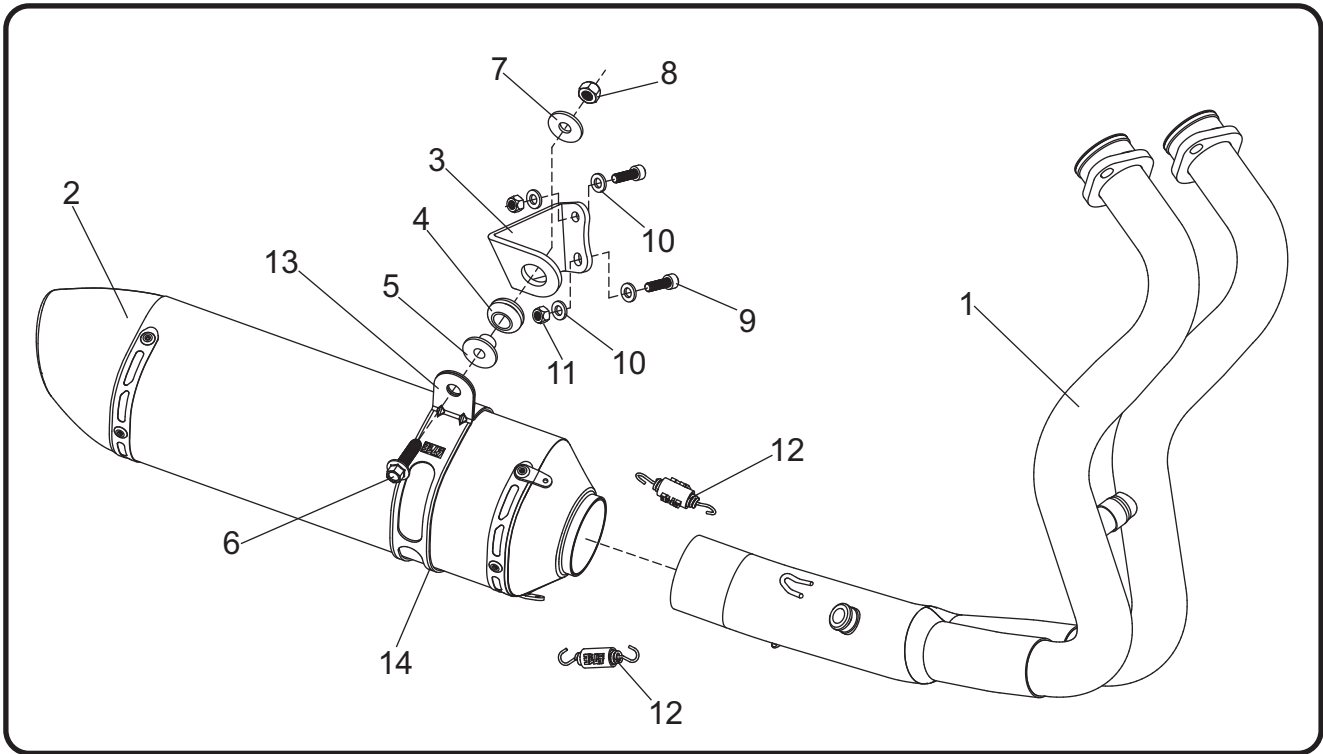

No.	Item	Description	Qty.
1	13700-401	Yoshimura Header	1
2	CRR77M12SA SRR77M12SA	Carbon Fiber Muffler Stainless Steel Muffler	1
3	13700-BRKT	Muffler Mount Bracket	1
4	Z1022	Rubber Bushing	1
5	ALS-003	Aluminum Spacer	1
6	M8X30H	8mm x 30mm Flanged Hex Head Bolt	1
7	8MMWASHERL	8mm Large Washer	1
8	8MMLN	8mm Nylon Lock Nut	1
9	M6X20	6mm x 20mm Socket Head Cap Bolt	2
10	6MMWASHER	6mm Washer	4
11	6MMLN	6mm Nylon Lock Nut	2
12	RACE-SPS-1	Medium Spring	2
13	YM7M-MPCA(X)	Muffler Clamp	1
14	HT SHLDR77	Muffler Clamp Heatshield	1
**	INS-04-K	Low Volume Insert	1
**	ST-200	Spring Puller Tool	1
**	17029	Sticker Kit Sheet	1

(X) Used for stainless steel muffler canister.  
 \*\* Not shown in diagram.

## Removal

1. Remove the O2 sensor from the stock header.
2. Remove the two bolts securing right side rearset to access muffler mount bolts.
3. Remove the left and right muffler mount bolts securing the stock muffler assembly onto muffler mount bracket.
4. While securely supporting the stock muffler assembly, remove the header nuts and carefully remove the stock muffler assembly.

Note<sup>1</sup>: Remove the stock left and right muffler mount brackets as it will not be used with the Yoshimura exhaust system.

Note<sup>2</sup>: The stock exhaust port gaskets will be re-used with the Yoshimura exhaust system. Inspect and replace if necessary.

## Installation

1. Install (No. 4) Z1022, rubber bushing into (No. 3) 13700-BRKT, muffler mount bracket.

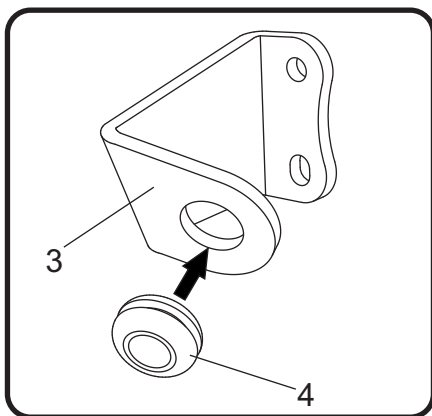

2. Install (No. 5) ALS-003, aluminum spacer into (No. 4) Z1022, rubber bushing as shown.

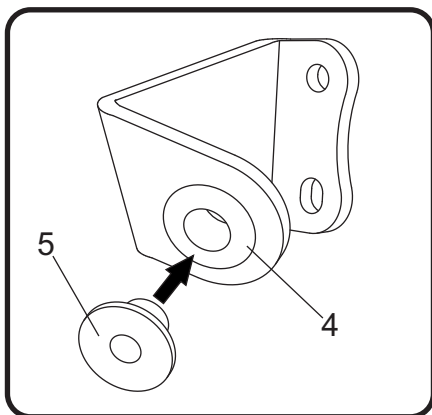

3. Install (No. 3) 13700-BRKT, muffler mount bracket onto frame using (No. 9) M6X20, 6mm bolt, (No. 10) 6MMWASHER, 6mm washer, and (No. 11) 6MMLN, 6mm nylon lock nuts as shown below.

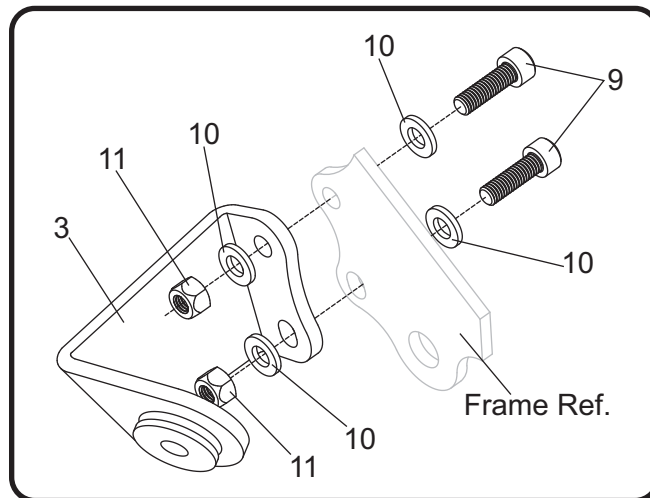

4. Install (No. 14) HT SHLDR77, muffler clamp heatshield onto (No. 13) YM7M-MPCA(X), muffler clamp.

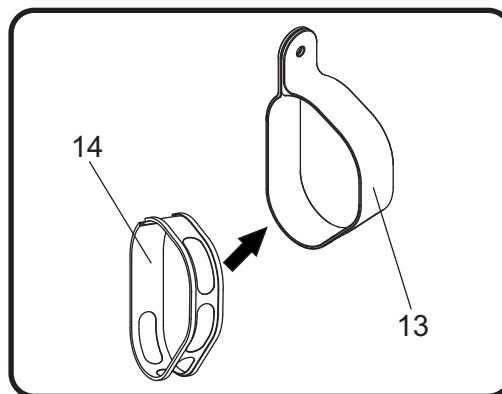

5. Install (No. 1) 13700-401, Yoshimura header using the stock header nuts. Do not torque at this time.
6. Install (No. 2) C/SRR77M12SA, Yoshimura muffler onto (No. 1) 13700-401, Yoshimura header.
7. Slide (No. 13) YM7M-MPCA(X), muffler clamp over (No. 2) C/SRR77M12SA, Yoshimura muffler and align to (No. 5) ALS-003, aluminum spacer installed into (No. 3) 13700-BRKT, muffler bracket. Secure using (No. 6) M8X30H, 8mm bolt, (No. 7) 8MMWASHERL, 8mm large washer, and (No. 8) 8MMLN, 8mm nylon lock nut. See assembly diagram for proper orientation and order of hardware.

8. Torque (No. 6) M8X30H, 8mm muffler mount bolt to factory specification.
9. Torque header nuts to factory specification.
10. Re-install the right rearset using the two stock bolts. Torque to factory specification.
11. Re-install the stock O2 sensor into (No. 1) 13700-401. Torque to factory specification.
12. Install (No. 12) RACE-SPS-1, medium exhaust springs between muffler and header connection.
13. Before starting vehicle, check for proper clearance between new exhaust system and rear suspension (i.e. tire, control arm, brakes, rear shock, and etc.) If any problem is found, please carefully follow through the installation steps again. If problem still persists, please call Yoshimura Tech Department at (800) 634-9166 / in CA (909) 628-4722.
14. It is recommended that the muffler and tailpipe be wiped down with rubbing alcohol to remove oil and fingerprints. This will help prevent tarnishing of the finish after the exhaust is heated up.

Note: After starting vehicle, it is normal for new exhaust system and muffler to emit smoke until oil residue burns off.