



RACE SERIES

Qualified Manufacturer Declared "Modified Part"

APPLICATION

YEAR	MODEL
2012-2018	Kawasaki ZX-14R

FOR CLOSED COURSE COMPETITION ONLY; NOT INTENDED FOR STREET USE

PRODUCT

1414020220	R77 SS Slip-On Exhaust with Carbon Fiber Sleeve; Carbon Fiber Endcap
1414020520	R77 SS Slip-On Exhaust with Stainless Steel Sleeve; Carbon Fiber Endcap

- ⚠ This product is designed for use in closed course racing and is not intended for highway use. In the state of California, it is illegal to modify the emission control system, which includes the fuel injection of any vehicle.
- ⚠ You must know how to remove and replace your stock exhaust in order to install this product otherwise have it installed by a professional mechanic. Keep all stock parts from your existing system as some components may be necessary to install your new Yoshimura exhaust depending on the application.
- ⚠ Read through all instructions before beginning installation. Exhaust system can be extremely hot. Let motorcycle cool down before beginning installation. Always wear hand and eye protection and take precautionary measures to avoid injury.

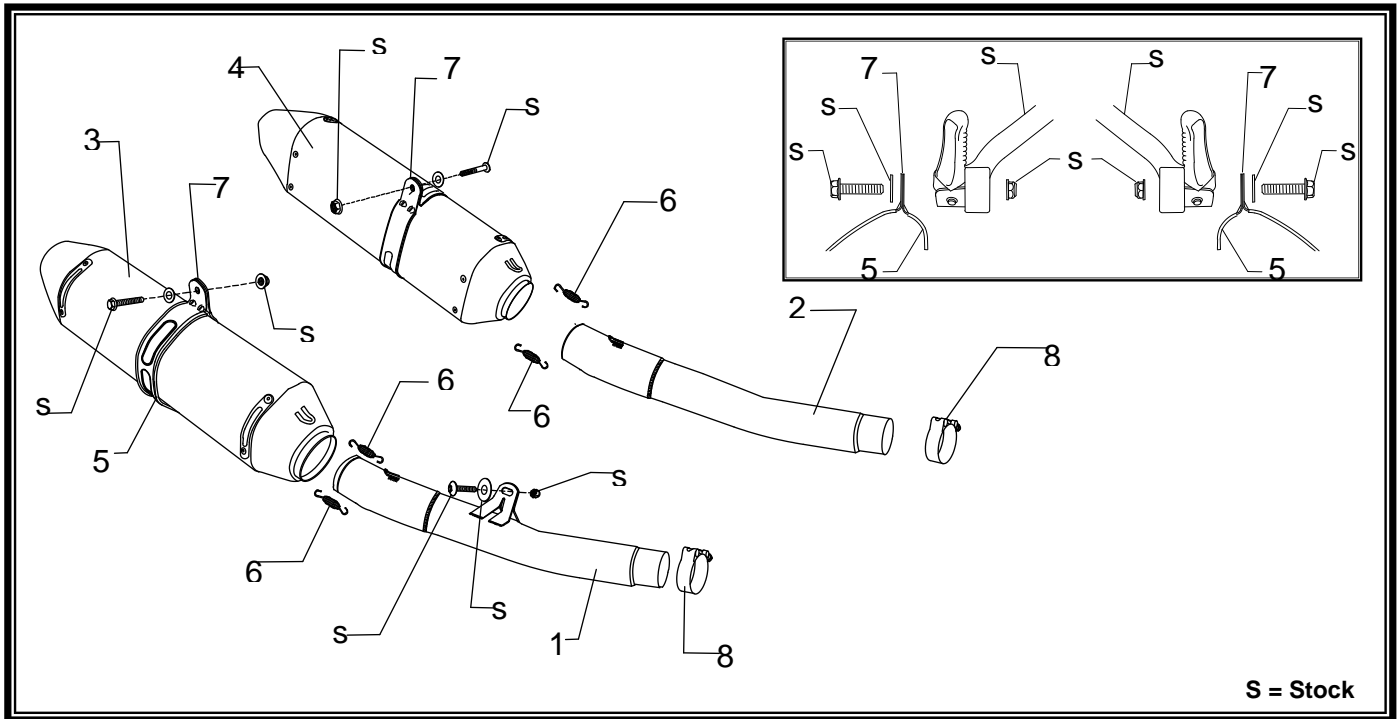

S = Stock

No.	Part #	Description	Qty
1	14140-427	Right Tailpipe	1
2	14140-426	Left Tailpipe	1
3	CRR77F146W SRR77F146W	Yoshimura Muffler CF Right Muffler Assembly SS Right Muffler Assembly	1
4	CRR77F146WL SRR77F146WL	Yoshimura Muffler CF Left Muffler Assembly SS Left Muffler Assembly	1
5	HT SHLDR77	Muffler Clamp Heat Insulator	2
6	RACE-SPS-1	Medium Spring	4
7	1426-MPCA 1426-MPCAX	Muffler Clamp CF Sleeve SS Sleeve	2
8	20063	Exhaust Clamp	2
**	INS-04-K	Low Volume Insert	2
**	ST-200	Spring Puller Tool	1
**	17029	Yoshimura Sticker Sheet	1

-TOOLS REQUIRED-

Metric Socket Set

Combination Wrench Set

Torque Wrench

Metric Allen Wrench Set

Screwdriver

-REMOVAL-

- 1. Remove lower rear cowling to ease removal of stock tailpipes.**
- 2. Remove the (2) bolts securing small heatshield to passenger footpeg. The stock passenger peg heatshield will not be used with the Yoshimura Slip-On System.**
- 3. Loosen exhaust clamps and while securely supporting the stock muffler, remove the muffler mount bolt to remove stock muffler assembly.**
Note: Stock exhaust gaskets will not be used with the Yoshimura Slip-On System.

-INSTALLATION-

- 1. Slide supplied exhaust clamps over Yoshimura tailpipe inlets.**
- 2. Install Yoshimura Slip-On system using stock hardware. See diagram for orientation. (Extra large stock muffler mount washers will not be used.)**
Note: Yoshimura muffler clamps mount on the outside of the stock muffler mount bracket. Yoshimura tailpipe brackets mount on the inside of the stock tailpipe mount locations.
- 3. Torque muffler mount bolts and tailpipe mount bolts to 25Nm. (2.5kg-m, 18lb-ft)**
- 4. Torque exhaust clamps to 11Nm. (1.1kg-m, 8lb-ft)**
- 5. Fitment check and Notes.**
 - a. Before starting motorcycle, check for proper clearance between new exhaust system and rear suspension (i.e. tire, swing-arm, brake, rear shock, engine, and etc.) If any problem is found, please carefully follow through the installation steps again. If problem still persists, please call Yoshimura Tech Department at (800) 634-9166 / in CA (909) 628-4722.**
 - b. It is recommended that the muffler and tailpipe be wiped down with rubbing alcohol to remove oil and fingerprints. This will help prevent tarnishing of the finish after the exhaust is heated up.**
 - c. NOTE: After starting motorcycle, it is normal for new exhaust system and muffler to emit smoke until oil residue burns off.**