



YOSHIMURA

RESEARCH&DEVELOPMENT OF AMERICA, INC.

5420 DANIELS STREET STE A, CHINO CA., 91710 · (800) 634-9166 · (909) 628-4722 · FAX (909) 591-2198

www.yoshimura-rd.com

Street Series

Qualified Manufacturer Declared "Replacement Part"

2010~2014
BMW S1000RR

2014~2016
BMW S1000R

1520487 (Ti/CF)
R-55 Titanium Slip-On System

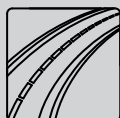

All Street Series systems are:

- Slip-on/Bolt-on applications that do not require tampering with the vehicle's emissions control system.
- CARB/EPA tail-pipe emissions compliant.
- Marked with appropriate EPA noise labels.
- Not tested for EPA new vehicle noise compliance.

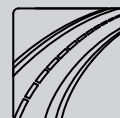

✘ *You must know how to remove and replace your stock exhaust in order to install this product otherwise have it installed by a professional mechanic. Keep all stock parts from your existing system as some components may be necessary to install your new Yoshimura exhaust depending on the application. Read through all instructions before beginning installation. Exhaust system can be extremely hot. Let motorcycle cool down before beginning installation. Always wear hand and eye protection and take precautionary measures to avoid injury.* ✘

NOTE: IN THE STATE OF CALIFORNIA, IT IS ILLEGAL TO MODIFY THE EMISSION CONTROL SYSTEM, WHICH INCLUDES THE CARBURETORS OF ANY VEHICLE.

Caution: Exhaust system can be extremely hot. Let motorcycle cool down before beginning installation. Always wear hand and eye protection and take precautionary measures to avoid injury.

Note: Read through all instructions before beginning installation.

Tools Needed:

3/8" ratchet and extension
Combination Wrench Set
Torque wrench
Torx Bit Set

Installation Steps:

1 Remove Stock Muffler

- Loosen stock muffler clamp behind heat shield.
- Remove stock muffler mount bolt connected to rearset (Fig. 1).
- Slide muffler off underbelly silencer outlet.

2 Install Yoshimura Muffler

- Loosen Yoshimura Carbon Fiber heatshield bolts.
- Slide Yoshimura muffler onto stock underbelly silencer outlet.
- Slide stock clamp around Yoshimura muffler inlet.
- Secure Yoshimura muffler to back side of rearset mount using stock bolt and aluminum spacer.
- Tighten muffler bracket mounting bolt to 14 ft-lbs (19 N-m).
- Align stock heatshield with Yoshimura Carbon Fiber heatshield such that there is a uniform gap between heatshields (Fig. 2).
- Tighten stock muffler clamp to 18 ft-lbs (25 N-m).
- Tighten Yoshimura Carbon Fiber Heat Shield mounting bolts to 7 ft-lbs (10 N-m).

3 It is recommended that the muffler and heatshields be wiped down with rubbing alcohol or other alcohol based cleanser to remove oil and fingerprints. This will help prevent tarnishing of the finish after the exhaust is heated up.

Check for proper clearance between new exhaust system and motorcycle (i.e. swing-arm, body work, etc.). If any problem is found, please carefully follow through the installation steps again. If problem still persists, please call Yoshimura technical department at (800)634-9166 / in CA (909)628-4722.

NOTE: After starting motorcycle, it is normal for a new exhaust system and muffler to smoke until oil residue burns off.

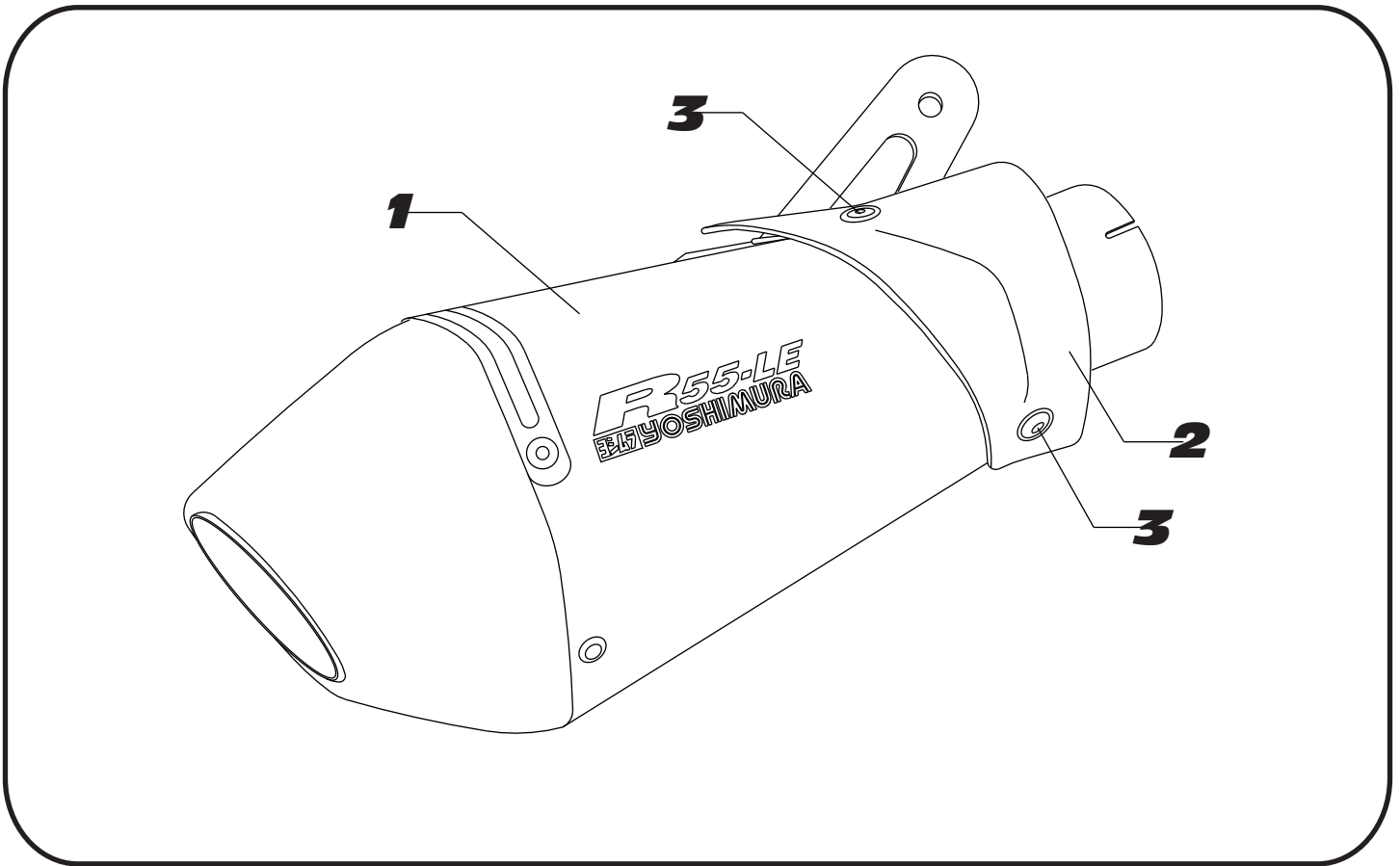

Fig. 1



Fig. 2

PN: 1520487



Part Diagram

NO.	DESCRIPTION	QTY	PART #
1	Yoshimura Titanium Carbon R55 Muffler	1	1520487-RMA
2	Carbon Fiber Heatshield	1	1520-CFHST-00
3	Heatshield Bolt	2	RC116HSB-BK
**	Yoshimura Vinyl Sticker	1	17029
**	Instruction Kit	1	INST KIT