



YOSHIMURA

RESEARCH&DEVELOPMENT OF AMERICA, INC.

5420 DANIELS STREET STE A, CHINO CA 91710 · (800)634-9166 · (909)628-4722 · FACSIMILE (909)591-2198

WWW.YOSHIMURA-RD.COM

SIGNATURE SERIES

KTM
450 SX-F

264601D220 (Ti/CF)
264601D720 (Ti/Ti)

Titanium RS4 Full-System

ENDURO SERIES

KTM
450 XC-F



Signature Series systems are:

- CARB/EPA tail-pipe emissions compliant.
- Marked with appropriate EPA noise labels.
- Independent laboratory tested for EPA new vehicle noise compliance.



Enduro Series systems are:

- Equipped with USFS-approved spark arrestor.
- CARB/EPA tail-pipe emissions compliant.
- All applications are marked with appropriate EPA noise labels.
- Have not been tested for EPA new vehicle noise compliance.



CAUTION: The muffler packing on this system **MUST** be replaced every 6-8 hours of use, or after each moto. Failure to follow recommended muffler re-packing interval can cause muffler damage and may void the warranty.



NOTE: IN THE STATE OF CALIFORNIA, IT IS ILLEGAL TO MODIFY THE EMISSION CONTROL SYSTEM, WHICH INCLUDES THE CARBURETORS OF ANY VEHICLE.

CAUTION: Exhaust system can be extremely hot. Let motorcycle cool down before beginning installation. Always wear hand and eye protection and take precautionary measures to avoid injury.

WARNING: Always properly support vehicle with a stand and/or lift when servicing or performing any work. Unstable vehicles may present dangerous conditions and may cause property damage, personal injury and/or death.

Note: Read through all instructions before beginning installation.

Tools Needed:

Metric Socket Set
Ratchet Wrench and Extension
Torque Wrench
Spring Puller Tool

Installation Steps:

1. Stock exhaust removal.

- Follow owner's manual instructions to remove stock silencer.
- Follow owner's manual instructions to remove shock assembly from the bike.
- Remove stock header from bike by removing the stock exhaust springs securing header to flange.
- Re-install shock assembly using the reverse steps of removal.

*Note*¹: Rear shock assembly may be re-installed after header is removed as the Yoshimura tailpipe is separated into two pieces.

*Note*²: Stock header flange springs will be re-used on the Yoshimura exhaust system.

2. Small parts installation.

- Install provided rubber grommets into muffler bracket.
- Install aluminum spacers into rubber grommet. See diagram for proper orientation.

3. Installing Yoshimura full-system.

- Install Yoshimura header onto stock manifold.
- Remove spring and tailpipe from muffler.

c. Install Yoshimura tailpipe onto Yoshimura header and secure to frame mount using supplied hardware. Frame mount washer goes between frame and tailpipe. Do not torque bolt or install springs at this time.

d. Install muffler onto Yoshimura tailpipe and secure using supplied hardware. Do not torque bolts or install springs at this time. See diagram for proper orientation and order of hardware.

e. Torque tailpipe mount to factory specification.

f. Torque muffler mounts to factory specification.

g. Install stock exhaust springs between header and flange, and supplied Yoshimura exhaust springs between header, tailpipe, and muffler.

4. Fitment check and notes.

Before starting motorcycle, check for proper clearance between new exhaust system and rear suspension (i.e. tire, swing-arm, brake, rear shock, engine etc). If any problem is found, please carefully follow through the installation steps again. If problem still persists, please call Yoshimura Tech Department at (800) 634-9166 / in CA (909) 628-4722.

It is recommended that the muffler and tailpipe be wiped down with rubbing alcohol to remove oil and fingerprints. This will help prevent tarnishing of the finish after the exhaust is heated up.

NOTE: After starting motorcycle, it is normal for new exhaust system and muffler to emit smoke until oil residue burns off.

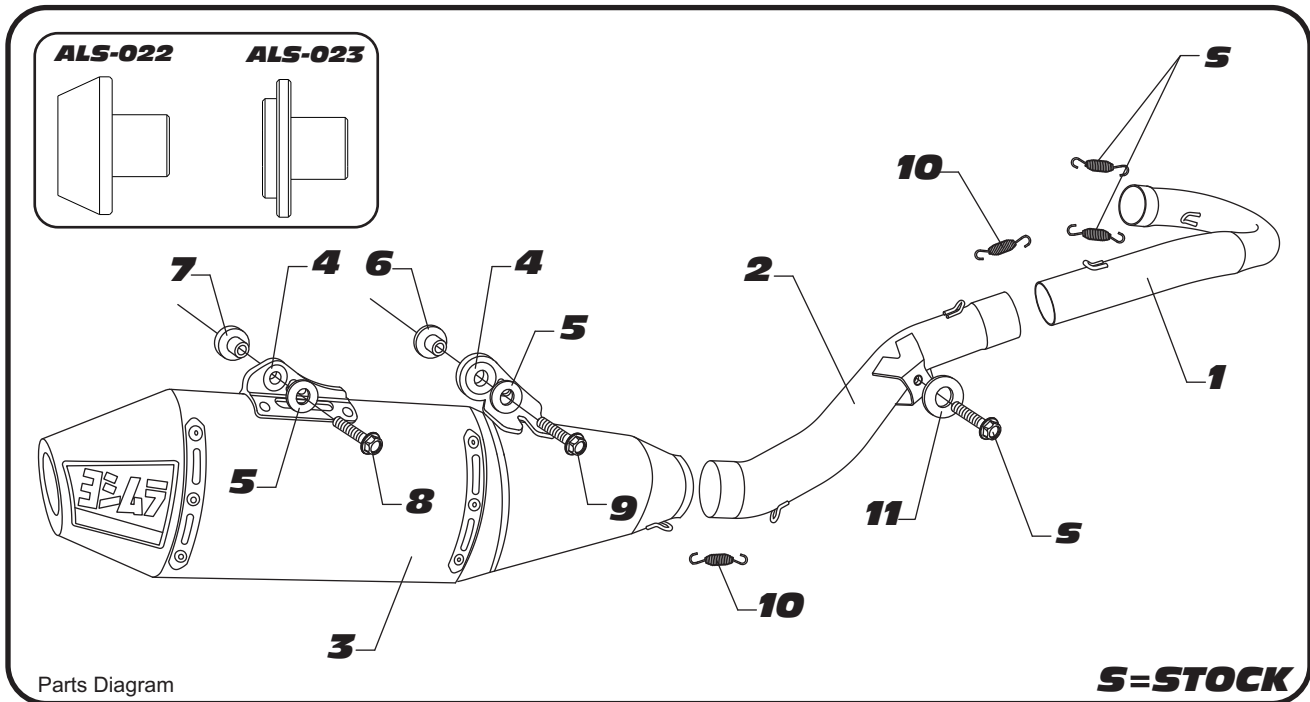

NO.	DESCRIPTION	QTY	PART #
1	Yoshimura Header	1	26460-704
2	Yoshimura Tailpipe	1	26460-744
	Yoshimura Muffer Assembly	1	
3	Carbon Fiber Sleeve Titanium Sleeve		264601D220-RMA 264601D720-RMA
4	Rubber Grommet	2	Z1022
5	6mm XL Flat Washer	2	6MMWASHERXL
6	Aluminum Spacer	1	ALS-023
7	Aluminum Spacer	1	ALS-022
8	6mm x 45mm Flanged Hex Head Bolt	1	M6X45H
9	6mm x 35mm Flanged Hex Head Bolt	1	M6X35H
10	Medium Exhaust Spring	2	RACE-SPS-1
11	8mm Large Flat Washer	1	8MMWASHERL
**	AMA 94dB Sound Insert (Installed)	1	INS-2M28-K
**	2m-MAX Insert Kit	1	INS-2M26-K
**	Spark Arrestor Kit (Enduro Series)	1	SA-04-K
**	Offroad Endcap Plug	1	347PLUG
**	Spring Puller Tool	1	ST-200
**	Yoshimura Vinyl Sticker	1	17029
OPTIONAL REPLACEMENT PARTS			
	Repack Kit		REPACK-RS4-PK11

IMPORTANT NOTE

Signature Series Applications:

The Yoshimura full-system comes pre-installed with the AMA 94 dB Sound Insert.

Enduro Series Applications:

The supplied spark arrestor and USFS decal MUST be installed on muffer before operating vehicle in order for legal use on public lands. Spark arrestor is USFS approved and 96dB or lower compliant.



YOSHIMURA

RESEARCH&DEVELOPMENT OF AMERICA, INC.

5420 DANIELS STREET SUITE A, CHINO, CA 91710 · (800)634-9166 · (909)628-4722 · FACSIMILE (909)591-2198

www.yoshimura-rd.com

INS-2M28-K

YOSHIMURA 2M MAX SOUND INSERT KIT

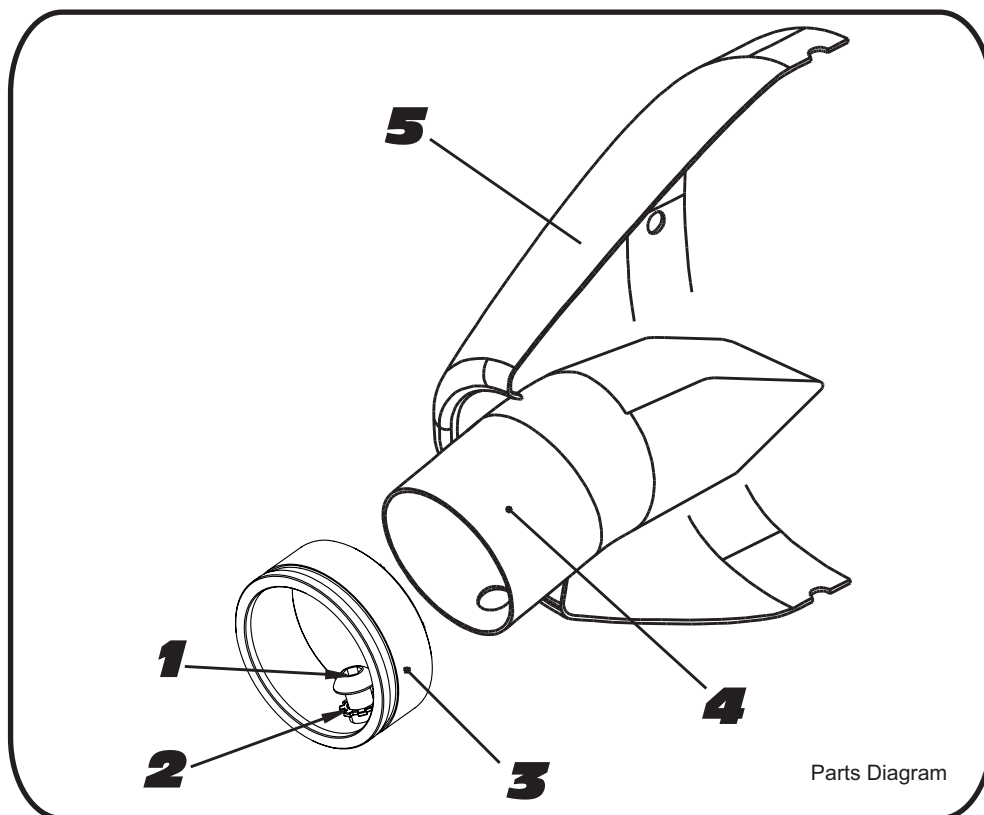

Parts Diagram

NO.	DESCRIPTION	QTY	PART #
1	6mm X 12mm Button Head Cap Screw	1	M6X12BHS
2	6mm Lock Washer	1	6MMLCKWSHR-TH
3	RS4 Spark Arrestor Ring 1.500"	1	RS4-RING-1500
4	RS4 2M Max Insert	1	INS-SSP-1.5X65
5	Yoshimura Exhaust	**	**

1. Using a 4mm Allen key, remove the bolt that secures the aluminum ring and sound insert to the muffler (see Parts Diagram for location).
2. Remove the sound insert from the muffler.
3. Inspect the sound insert for cracks or damage and replace if necessary.
4. Install sound insert and aluminum ring. Torque the sound insert securing bolt to 1.0 kg-m (7.3 lb-ft).
NOTE: It is recommended that a low strength "Loc-tite" is used on the sound insert securing bolt.