

SUZUKI® INSTALLATION INSTRUCTIONS

Description: Rear Rack
Applications: 2004- LT-Z400

Part Number: 99950-70538
Installation Time: .2 hours

Contents:

Reference#	Description	Qty
1	Aluminum Rear Rack	1
2	8mm X 16mm Flange Head Bolt	4

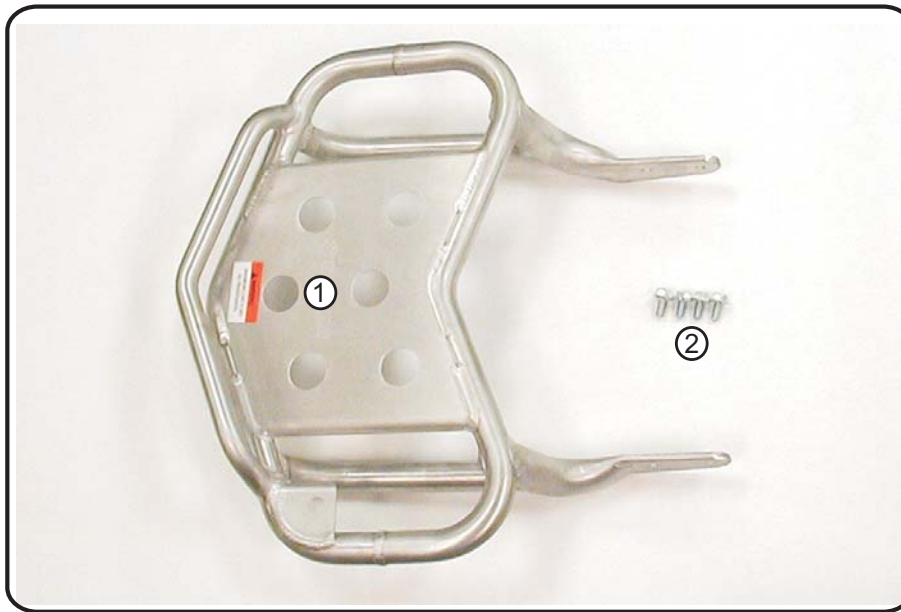

Tools Required:

Tools Description
10mm & 12mm Socket
Ratchet Wrench
Torque Wrench



Important:

Please read this manual and follow the instructions carefully. To emphasize special information, the symbol  and the words WARNING, CAUTION, And *NOTE* have special meanings. Pay special attention to the messages highlighted by these signal words.

 **WARNING**

WARNING
Indicates potential hazard that could result in death or injury.

CAUTION

CAUTION
Indicates potential hazard that could result in vehicle damage.

NOTE:

NOTE: Indicates special information to make maintenance easier or instructions clearer.

Preparation Prior to Installation

Read instructions carefully. Lay out all parts and tools in a clean area. Visually inspect parts for possible damage from shipping.

WARNING

Engine and exhaust system can be extremely hot. Let ATV cool down before beginning installation.

GENERAL PRECAUTIONS

WARNING

- * Proper service and repair procedures are important for the safety of the service mechanic and the safety and reliability of the ATV.
- * When two or more persons work together, pay attention to the safety of each other.
- * When it is necessary to run the engine indoors, make sure the exhaust gas is forced outdoors.
- * When working with toxic or flammable materials, make sure the area you work in is well ventilated and that you follow all of the manufacturer's instructions.
- * Never use gasoline as a cleaning solvent.
- * To avoid getting burned, do not touch the engine, engine oil, radiator, and exhaust system until they have cooled.

CAUTION

- * If parts replacement is necessary, replace the parts with SUZUKI Genuine Parts or their equivalent.
- * When removing parts that are to be reused, keep them arranged in an orderly manner so that they may be reinstalled in the proper order.
- * Use a torque wrench to tighten fasteners to the specified torque. Wipe off grease and oil if a thread is smeared with them.
- * After reassembling, check parts for tightness and proper operation.

Installation:

NOTE: Performance rear rack is designed to install over the top of the stock rear subframe.

1. Remove mounting bolts from stock grab rail and rear fender support brackets on both sides.

NOTE: During installation it is recommended that Suzuki Thread Lock "1342" Pn# 99000-32050 be used on the 8mm mounting bolts.

2. Place performance rear rack into position. Install rear fender support brackets (See Fig. 1) to inside of rack, install 8 x 16mm bolts (Leave bolts loose).
3. Check performance rack alignment from the rear and sides. Adjust alignment as needed.
4. Torque 8mm bolts to 13 n.m. (9.5 lb ft).

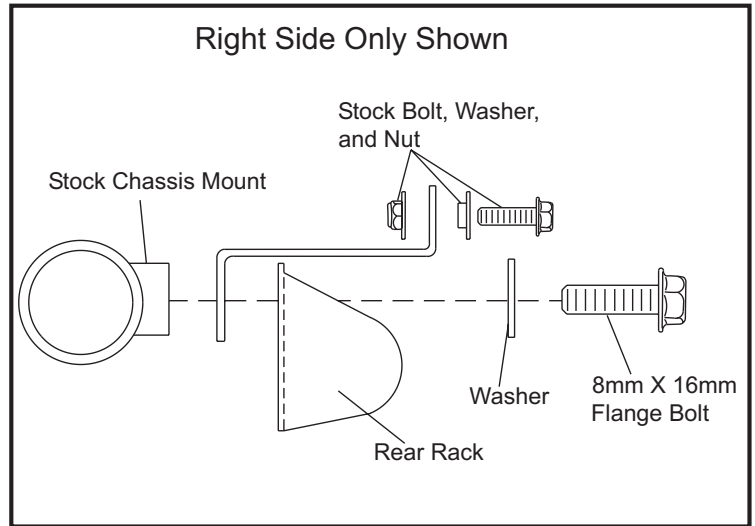

Fig. 2

⚠ WARNING

Never carry passengers on rear rack. Rack weight limit is 6 lbs.

Maintenance/Inspections:

Inspecting and checking torque for mounting bolts is advised after the first **2 hours** of operation, then once every 30-40 hours of operation.

Troubleshooting:

In the event of riding mishap where the performance rear grab rail comes in contact with the ground or other objects, it is recommended that the ATV and performance rear grab rail be carefully inspected for damage and secure fit. If in doubt, replace damaged Components.