



# YOSHIMURA

RESEARCH&DEVELOPMENT OF AMERICA, INC.

5420 DANIELS STREET SUITE A, CHINO, CA 91710 · (800)634-9166 · (909)628-4722 · FACSIMILE (909)591-2198

[www.yoshimura-rd.com](http://www.yoshimura-rd.com)

**NS-16K**

**YOSHIMURA RS4 LOW VOLUME INSERT KIT**

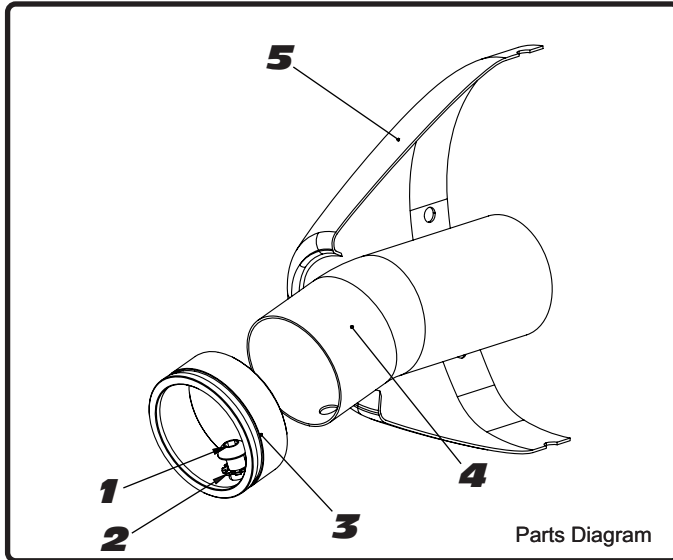

| NO. | DESCRIPTION                      | QTY | PART #        |
|-----|----------------------------------|-----|---------------|
| 1   | 6mm X 12mm Button Head Cap Screw | 1   | M6X12BHS      |
| 2   | 6mm Lock Washer                  | 1   | 6MMLCKWSHR-TH |
| 3   | RS4 Aluminum Insert Ring         | 1   | RS4-RING-1375 |
| 4   | Low Volume Sound Insert          | 1   | INS-W-01      |
| 5   | Yoshimura Exhaust                | **  | **            |

1. Remove small allen head bolt.
2. Remove current insert and ring.
3. Insert the Yoshimura insert into the end of the muffler and secure using the small allen head bolt and 6mm lock washer.

**NOTE:** It is recommended that a low strength "Loc-tite" is used on the small allen head bolt.



# YOSHIMURA

RESEARCH&DEVELOPMENT OF AMERICA, INC.

5420 DANIELS STREET SUITE A, CHINO, CA 91710 · (800)634-9166 · (909)628-4722 · FACSIMILE (909)591-2198

[www.yoshimura-rd.com](http://www.yoshimura-rd.com)

**NS-16K**

**YOSHIMURA RS4 LOW VOLUME INSERT KIT**

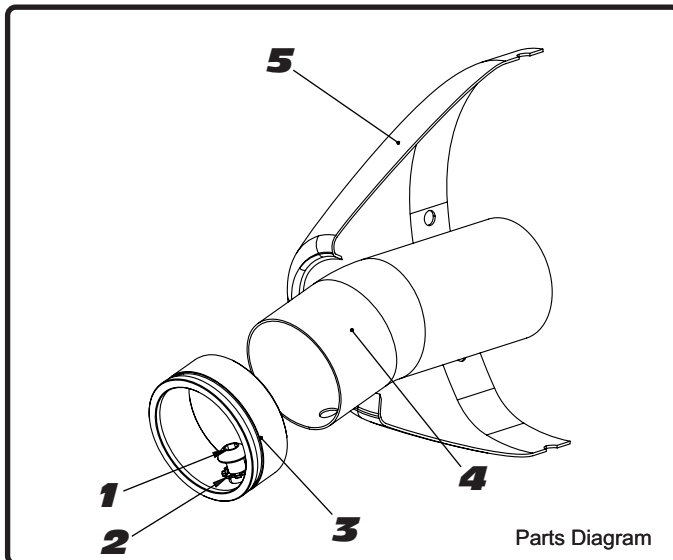

| NO. | DESCRIPTION                      | QTY | PART #        |
|-----|----------------------------------|-----|---------------|
| 1   | 6mm X 12mm Button Head Cap Screw | 1   | M6X12BHS      |
| 2   | 6mm Lock Washer                  | 1   | 6MMLCKWSHR-TH |
| 3   | RS4 Aluminum Insert Ring         | 1   | RS4-RING-1375 |
| 4   | Low Volume Sound Insert          | 1   | INS-W-01      |
| 5   | Yoshimura Exhaust                | **  | **            |

1. Remove small allen head bolt.
2. Remove current insert and ring.
3. Insert the Yoshimura insert into the end of the muffler and secure using the small allen head bolt and 6mm lock washer.

**NOTE:** It is recommended that a low strength "Loc-tite" is used on the small allen head bolt.