



YOSHIMURA

RESEARCH&DEVELOPMENT OF AMERICA, INC.

5420 DANIELS STREET SUITE A, CHINO, CA 91710 · (800)634-9166 · (909)628-4722 · FACSIMILE (909)591-2198

www.yoshimura-rd.com

INS-BD-K YOSHIMURA RS4D LOW VOLUME INSERT KIT

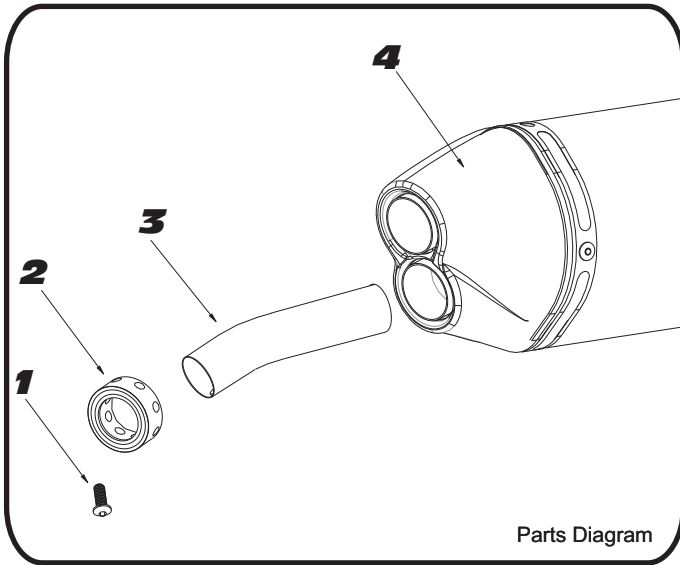

NO.	DESCRIPTION	QTY	PART #
1	5mm x 10mm Screw	1	M5X10 BOLT
2	RS4D Bottom Ring 1.000"	1	RS4D-RING-1000
3	RS4D Bottom Low Volume Insert	1	INS-BD
4	Yoshimura Exhaust	**	**

- 1 Remove muffler from tailpipe.
- 2 Insert the front insert into the tailpipe.
- 3 Reinstall the muffler.
- 4 Insert the rear insert into the end of the muffler and secure using the small allen head bolt.

NOTE: It is recommended that a low strength "Loc-tite" is used on the small allen head bolt.



YOSHIMURA

RESEARCH&DEVELOPMENT OF AMERICA, INC.

5420 DANIELS STREET SUITE A, CHINO, CA 91710 · (800)634-9166 · (909)628-4722 · FACSIMILE (909)591-2198

www.yoshimura-rd.com

INS-BD-K YOSHIMURA RS4D LOW VOLUME INSERT KIT

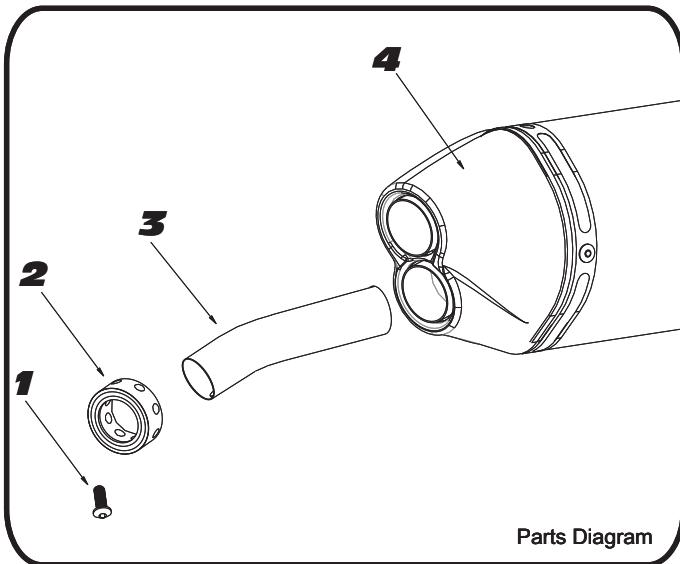

NO.	DESCRIPTION	QTY	PART #
1	5mm x 10mm Screw	1	M5X10 BOLT
2	RS4D Bottom Ring 1.000"	1	RS4D-RING-1000
3	RS4D Bottom Low Volume Insert	1	INS-BD
4	Yoshimura Exhaust	**	**

- 1 Remove muffler from tailpipe.
- 2 Insert the front insert into the tailpipe.
- 3 Reinstall the muffler.
- 4 Insert the rear insert into the end of the muffler and secure using the small allen head bolt.

NOTE: It is recommended that a low strength "Loc-tite" is used on the small allen head bolt.