



# YOSHIMURA

RESEARCH&DEVELOPMENT OF AMERICA, INC.

5420 DANIELS STREET STE A, CHINO CALIF. 91786 · (800)634-9166 · (909)628-4722 · FACSIMILE (909)591-2198

[www.yoshimura-rd.com](http://www.yoshimura-rd.com)

## Replacement Left Side Bracket Kit

**Kawasaki**  
**2008-2010 Ninja 250R**

**PN: R-K930BPL-K**

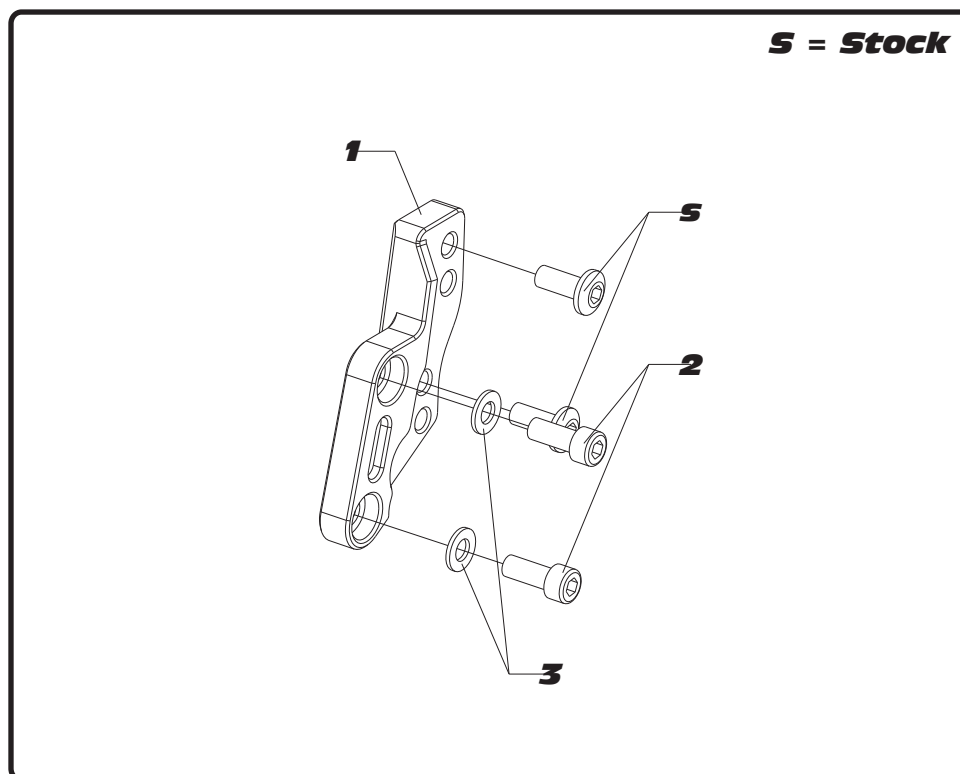

Parts Diagram

### Parts List:

	DESCRIPTION	QTY	PART #
1	Left Side Bracket	1	R-K930BPL-00
2	8mm X 20mm Bolt	2	M8X20
3	8mm Stainless Flat Washer	2	8MMWASHER-SS
**	Yoshimura *USA* Sticker	1	17020C

### Adjustable Positions:

Upper Position	Back	43mm
	Up	35mm
Lower Position	Back	43mm
	Up	20mm

**Caution: Always wear proper protective gear when performing work on vehicles.**

**Note: Read through all instructions before beginning installation. THIS INSTRUCTION SET INCLUDES STEPS FOR THE COMPLETE KIT. THIS KIT ONLY INCLUDES THE SPECIFIED REPLACEMENT PART AND NOT THE REMAINING COMPONENTS.**

## Tools Needed:

6mm Hex Bit and Ratchet  
10mm Open Ended Wrench  
Torque wrench  
Tube Cutter

## Installation Steps:

1. Remove stock shifter rod by loosening shift rod lock nuts and removing shift arm. Remove stock right rearset from frame by removing 2 bolts.
2. Clean stock bolts and apply a medium strength thread lock (included) to stock and supplied bolts. See parts diagram to install Yoshimura right rearset bracket to frame using supplied bolts and washer. Install stock rearset onto desired position (See Fig. 1). See chart on front page for positions available.

Torque to 18.5 ft-lbs ( 25 N-m ).

Note: Stock bolts will be used on stock rearset to Yoshimura rearset bracket. Supplied bolts and washers are to be used to mount Yoshimura rearset bracket and frame.

3. Remove stock lock nuts from stock shift rod and install onto Yoshimura shift rod. Install Yoshimura shift rod onto shift lever and shift arm. **Be sure to check position and clearance of shift lever action before operating motorcycle.** Tighten lock nuts.
4. Remove right rearset by removing stock bolts.
5. Clean stock bolts and apply a medium strength thread lock (included) to stock and supplied bolts. See parts diagram to install Yoshimura right rearset bracket to frame using supplied bolts and washer. Install stock rearset onto desired position (See Fig. 2). See chart on front page for positions available.

Note: Stock bolts will be used on stock rearset to Yoshimura rearset bracket. Supplied bolts and washers are to be used to mount Yoshimura rearset bracket and frame.

Torque to 18.5 ft-lbs ( 25 N-m ).

6. The rear brake reservoir hose will need to be shortened by 65mm so as not to cause binding and/or contact with other components. Remove rear brake reservoir hose, being sure not to spill brake fluid over painted or coated surfaces. Shorten the reservoir hose using tube cutter or sharp scissors. Reconnect hose and top off rear brake reservoir.

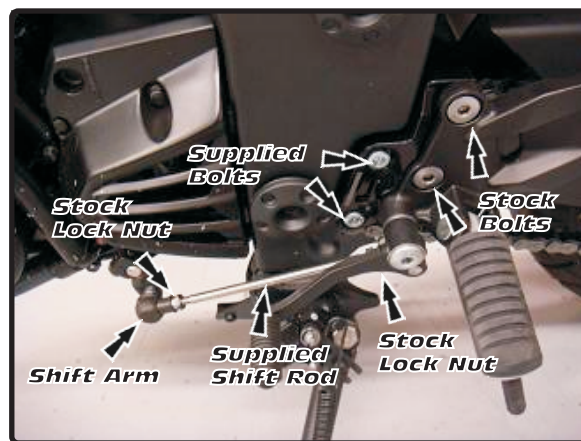

Fig. 1

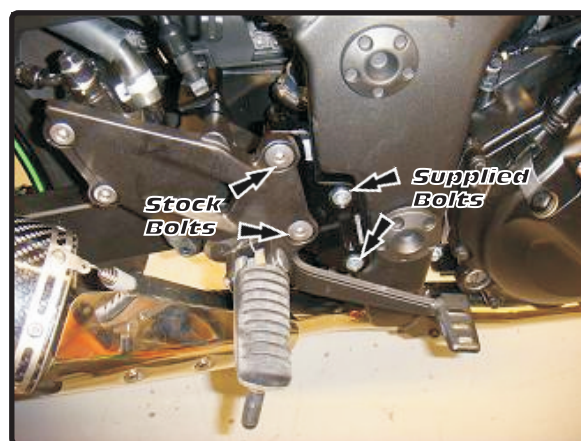

Fig. 2