



# YOSHIMURA

RESEARCH&DEVELOPMENT OF AMERICA, INC.

5420 DANIELS STREET SUITE A, CHINO, CA 91710 · (800)634-9166 · (909)628-4722 · FACSIMILE (909)591-2198

[www.yoshimura-rd.com](http://www.yoshimura-rd.com)

**SA-12-K**

**YOSHIMURA TEC-SD13 SPARK ARRESTOR KIT**

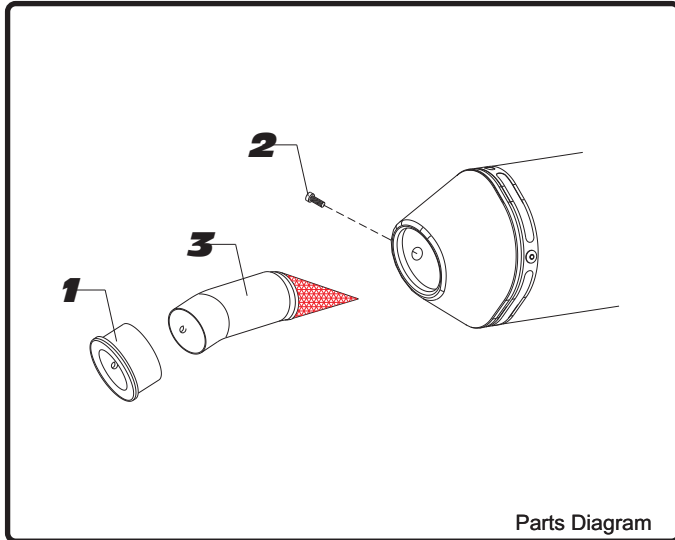

NO.	DESCRIPTION	QTY	PART #
1	6mm X 22mm Button Head Cap Screw	1	M6X22BHS
2	RS2 Insert Ring, 1.375"	1	DS4-RING-1375
3	TEC-SD13 Spark Arrester	1	TEC-SD13

- 1 Using a 4mm Allen key, remove the screw that secures the aluminum ring and spark arrester to the muffler (see Parts Diagram for location).
- 2 Remove the spark arrester from the muffler.
- 3 Using a wire brush, remove carbon deposits from spark arrester screen. Inspect the screen for excessive wear or damage. If spark arrester is excessively worn or damaged, the spark arrester must be replaced. Cleaning and inspection should be performed after every 60 hours of use.

**CAUTION:** Gloves and safety glasses should be worn while cleaning spark arrester.

- 4 Re-install spark arrester and aluminum ring. Torque the spark arrester securing screw to 1.0 kg-m (7.3 lb-ft).  
**NOTE:** It is recommended that a low strength thread lock is used on the spark arrester securing screw.



# YOSHIMURA

RESEARCH&DEVELOPMENT OF AMERICA, INC.

5420 DANIELS STREET SUITE A, CHINO, CA 91710 · (800)634-9166 · (909)628-4722 · FACSIMILE (909)591-2198

[www.yoshimura-rd.com](http://www.yoshimura-rd.com)

**SA-12-K**

**YOSHIMURA TEC-SD13 SPARK ARRESTOR KIT**

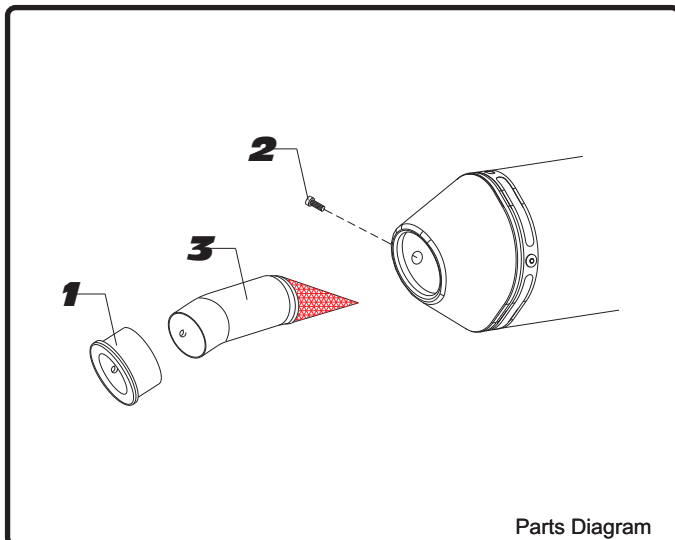

NO.	DESCRIPTION	QTY	PART #
1	6mm X 22mm Button Head Cap Screw	1	M6X22BHS
2	RS2 Insert Ring, 1.375"	1	DS4-RING-1375
3	TEC-SD13 Spark Arrester	1	TEC-SD13

- 1 Using a 4mm Allen key, remove the screw that secures the aluminum ring and spark arrester to the muffler (see Parts Diagram for location).
- 2 Remove the spark arrester from the muffler.
- 3 Using a wire brush, remove carbon deposits from spark arrester screen. Inspect the screen for excessive wear or damage. If spark arrester is excessively worn or damaged, the spark arrester must be replaced. Cleaning and inspection should be performed after every 60 hours of use.

**CAUTION:** Gloves and safety glasses should be worn while cleaning spark arrester.

- 4 Re-install spark arrester and aluminum ring. Torque the spark arrester securing screw to 1.0 kg-m (7.3 lb-ft).  
**NOTE:** It is recommended that a low strength thread lock is used on the spark arrester securing screw.