



YOSHIMURA

RESEARCH&DEVELOPMENT OF AMERICA, INC.

5420 DANIELS STREET SUITE A, CHINO, CA 91710 · (800) 634-9166 · (909) 628-4722 · FAX (909) 591-2198

www.yoshimura-rd.com

SA-15-K | SA-RS9-B Spark Arrestor Cleaning Information

Not for use with Carbon Fiber Sleeve

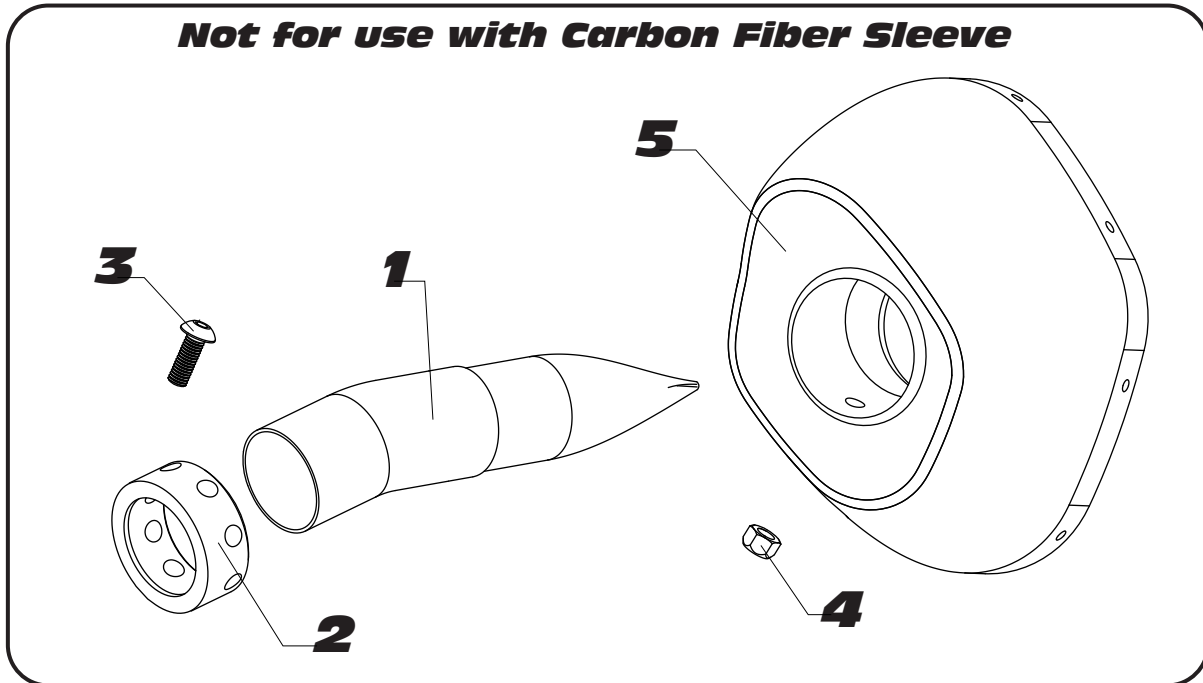

Parts Diagram

NO.	DESCRIPTION	QTY	PART #
1	RS9 Spark Arrestor	1	SA-RS9-B
2	RS9 Insert Ring	1	RS9-RING-1125
3	5mm x 14mm Button Head Screw	1	M5X14BHS
4	5mm Lock Nut	1	5MMLN-U
5	Yoshimura Exhaust	**	**
**	USFS Spark Arrestor Label	1	17086

Tools Needed: 4mm Allen Key • 8mm Deep Socket • Wire Brush • Pair of Gloves • Safety Glasses

- Using a 4mm allen key and 8mm deep socket, remove the bolt and nut that secures the aluminum ring and spark arrestor to the muffler (see Parts Diagram).
- Remove the spark arrestor from the muffler.
- Using a wire brush, remove carbon deposits from spark arrestor screen. Inspect the screen for excessive wear or damage. If spark arrestor is excessively worn or damaged, the spark arrestor must be replaced. Cleaning and inspection should be performed after every 60 hours of use.

CAUTION: Gloves and safety glasses should be worn while cleaning spark arrestor.

- Re-install spark arrestor and aluminum ring. Torque the spark arrestor securing bolt to 1.0kg-m (7.3lb-ft).
NOTE: It is recommended that a low strength "Loc-tite" is used on the spark arrestor securing bolt.
- Apply provided USFS certified spark arrestor label on the top rear of the muffler sleeve where visible

Note: Clean muffler surface with rubbing alcohol before applying label.