

YOSHIMURA CYCLING

5420 DANIELS STREET STE A, CHINO CA., 91710 · (800) 634-9166 · (909) 628-4722 · FAX (909) 591-2198

www.yoshimuracycling.com

⚠ READ THIS MANUAL BEFORE INSTALLING PEDALS. ⚠

WARNINGS TO USERS & PARENTS / GUARDIAN

- Proper installation and use of these pedals in accordance with the manual are essential for the safety of all users.
- Parents/Guardians must ensure that the correct procedures for installation and use of this product are followed and understood by the minor.
- Misuse or failure to follow the specified installation instructions and heed warnings may result in injury or death.

WARNING

- Always wear a helmet and follow trail etiquette when riding.
- Use headlights and taillights when riding in poor visibility conditions.
- Check leg extension after pedal installation and adjust saddle height if necessary.

WARRANTY

- All Yoshimura pedals carry a one-year limited warranty against defect in workmanship and/or materials and is only provided to the original purchaser. Original receipt or invoice will be required for processing.
- Damages caused by abuse, misuse, lack of service, improper installation and/or modifications are not covered under this warranty and are specifically disclaimed.
- For more warranty information, please visit www.yoshimuracycling.com.

CHILAO - Small Platform Pedals

Part #	Pedal Color	Pin Color
1FP2GYBL2	Pewter	Blue
1FP2GYPL2		Purple
1FP2GYBG2		Black

CARE & MAINTENANCE

- Periodically inspect pedals for wear, damage, or loose components before each ride.
- Gently wipe pedals with a damp cloth. Never power wash or spray water directly into dust seal.
- The Yoshimura pedal is designed and engineered to keep moisture and debris out of the internal structure and components. Maintaining clean pedals with properly lubricated internal components will maximize the longevity of the pedals.
- Yoshimura re-build services as well as service kits are available. Contact Yoshimura Tech Department at (800) 634-9166 / in CA (909) 628-4722 or visit www.yoshimuracycling.com.

Left side pedal is indicated with "L" and the spindle threads will slope up toward the left.
Left spindle also has a machined groove to easily identify.

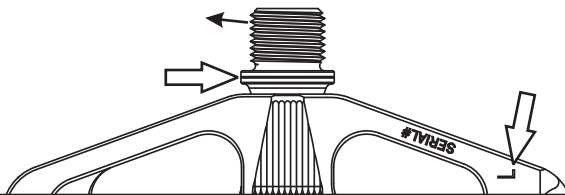

Right side pedal is indicated with "R" and the spindle threads will slope up toward the right.

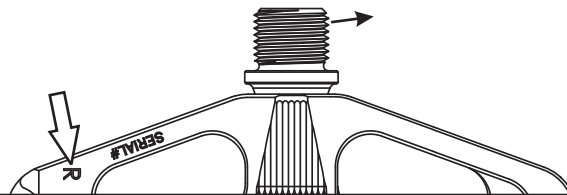

Grease spindle and start spindle threads into crank arm by hand.
Using an 8mm hex wrench, tighten spindle onto crank.
Consult your crank manufacturer for proper torque specifications.
Re-use pedal washers if equipped with your crank.

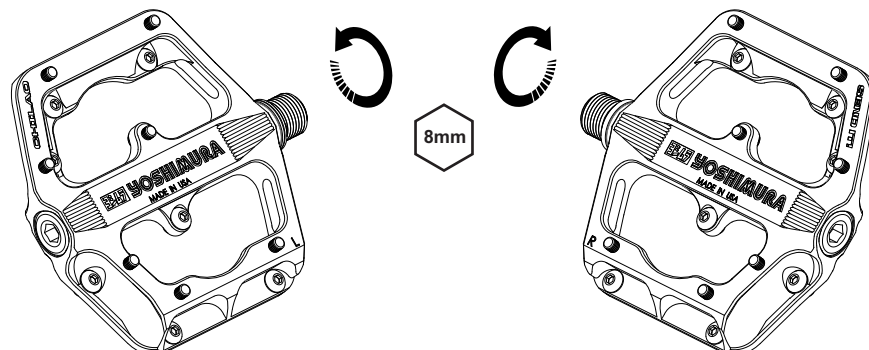

Assembly Diagram

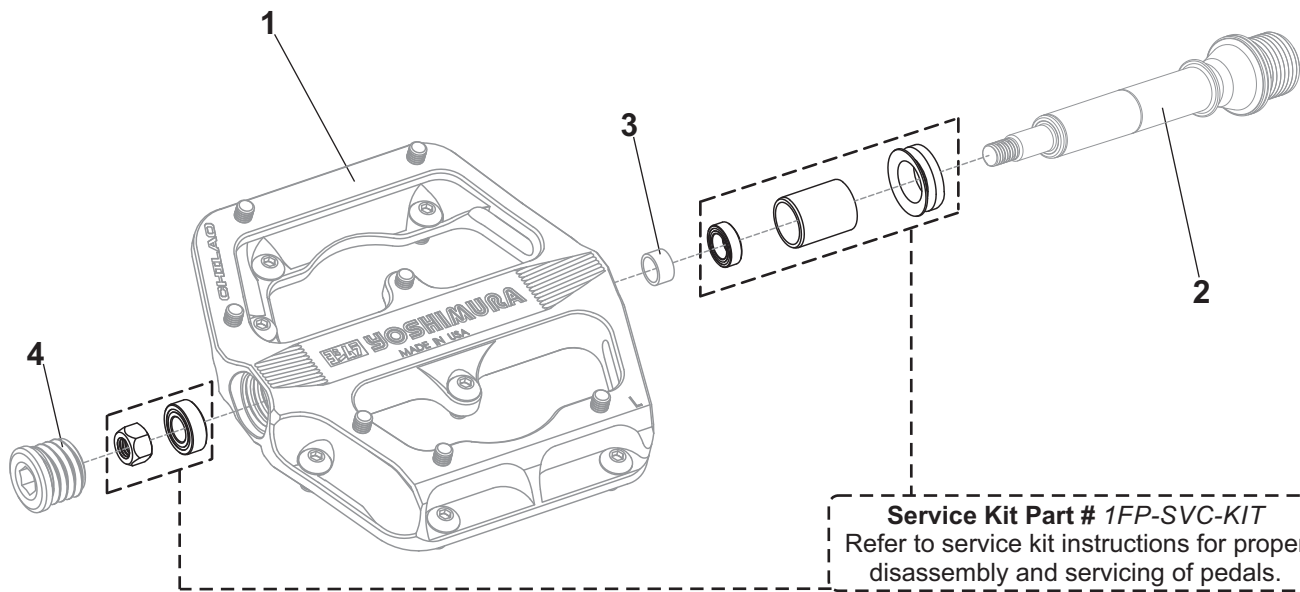

No.	Item	Description	Qty.
1	1FP2GY-L1	Pewter Pedal, Left	1
1	1FP2GY-R1	Pewter Pedal, Right	1
2L	1FP-SPDL-LH2	Spindle, Left	1
2R	1FP-SPDL-RH2	Spindle, Right	1
3	1FP-BRG-SPCR	Bearing Spacer	2
4	1FP-PLUG	Pedal End Plug	2
**	M4X8BHS-AL-BL	M4 x 8mm Blue Pins	28
	M4X8BHS-AL-PL	M4 x 8mm Purple Pins	
	M4X8BHS-AL-BG	M4 x 8mm Black Pins	
**	17118	Cycling Sticker Sheet	1
Optional Parts			
	1FP-SVC-KIT	Flat Pedal Service Kit (Left & Right)	
	M4X6BHS-AL-BL	M4 x 6mm Blue Pins	
	M4X6BHS-AL-PL	M4 x 6mm Purple Pins	
	M4X6BHS-AL-BG	M4 x 6mm Black Pins	

** Not shown on diagram.