

YOSHIMURA CYCLING

5420 DANIELS STREET STE A, CHINO CA., 91710 · (800) 634-9166 · (909) 628-4722 · FAX (909) 591-2198

www.yoshimuracycling.com



**READ THIS MANUAL BEFORE
INSTALLING STEM KIT**



WARNINGS TO USERS & PARENTS / GUARDIANS

- Proper installation and use of this stem in accordance with the manual are essential for the safety of all users.
- Parents/Guardians must ensure that the correct procedures for installation and use of this product are followed and understood by the minor.
- Misuse or failure to follow the specified installation instructions and heed warnings may result in injury or death.

WARNING

- Always wear a helmet and follow trail etiquette when riding.

WARRANTY

- All Yoshimura stem kits carry a one-year limited warranty against defect in workmanship and/or materials and is only provided to the original purchaser. Original receipt or invoice will be required for processing.
- Damages caused by abuse, misuse, lack of service, improper installation and/or modifications are not covered under this warranty and are specifically disclaimed.
- For more warranty information, please visit www.yoshimuracycling.com.

DH Stem Kit

Part #	Description
DH35-45-PW	45mm Stem Kit, Pewter
DH35-50-PW	50mm Stem Kit, Pewter
DH35-55-PW	55mm Stem Kit, Pewter
DH35-45-YK	45mm Stem Kit, Yoshikote
DH35-50-YK	50mm Stem Kit, Yoshikote
DH35-55-YK	55mm Stem Kit, Yoshikote

CARE & MAINTENANCE

- In the event of a crash inspect for wear, damage, or loose components.
- Periodically clean dirt & debris off stem.
- Contact Yoshimura Tech Department at (800) 634-9166 / in CA (909) 628-4722 or visit www.yoshimuracycling.com.



Stem kit is pre-assembled out of the box with all bolts hand-tight. Remove all bolts and apply grease to threads when installing.

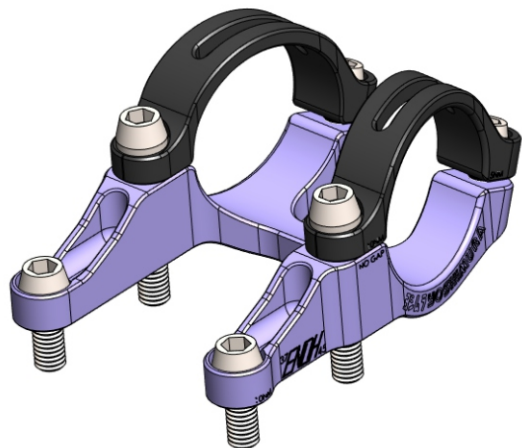

Single Crown Reach

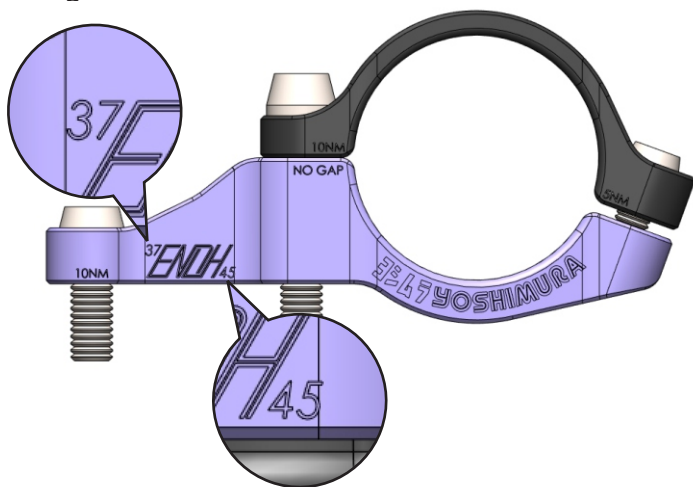

DH Direct Mount Reach

Installation

1. Clean handlebar.
2. Grease 6mm x 16mm bolts and install clamp base directly to front fork. Do not torque at this time.

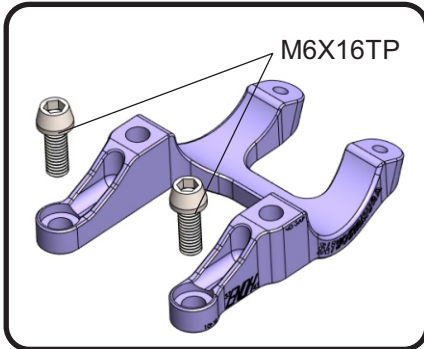

3. Grease 6mm x 35mm bolts and install handlebar and upper clamps. Do not torque at this time.

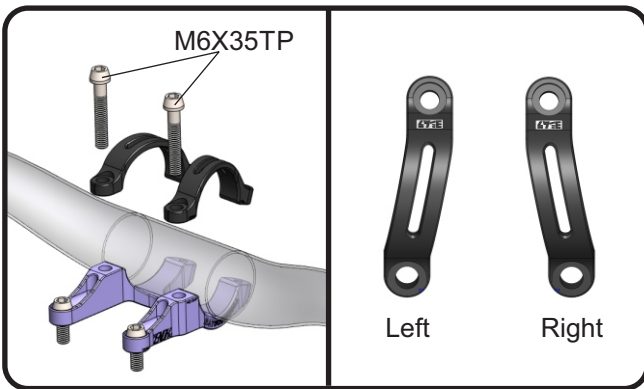

4. Grease 5mm x 12mm bolts and hand tight forward clamp bolts to desired handlebar alignment. Do not torque at this time. Leave minimum 2mm gap as shown.

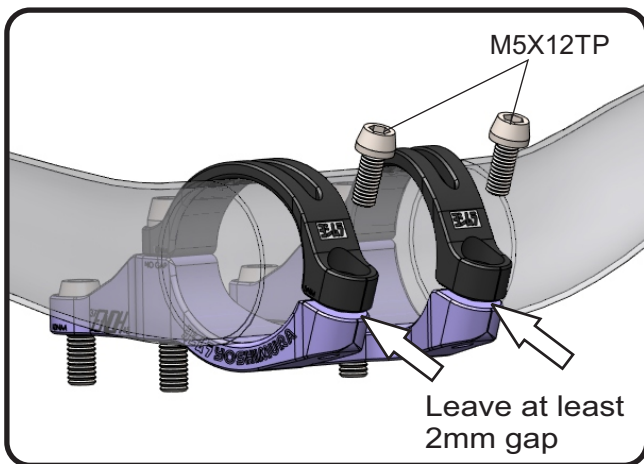

5. Torque the four clamp base bolts to 10 Nm.

Note: There should be no gaps between clamp base and upper clamp as shown.

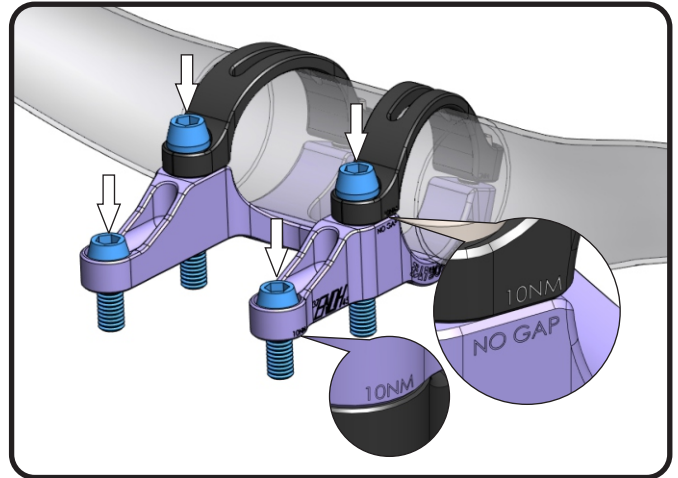

6. Torque the two forward clamp bolts to 5 Nm.

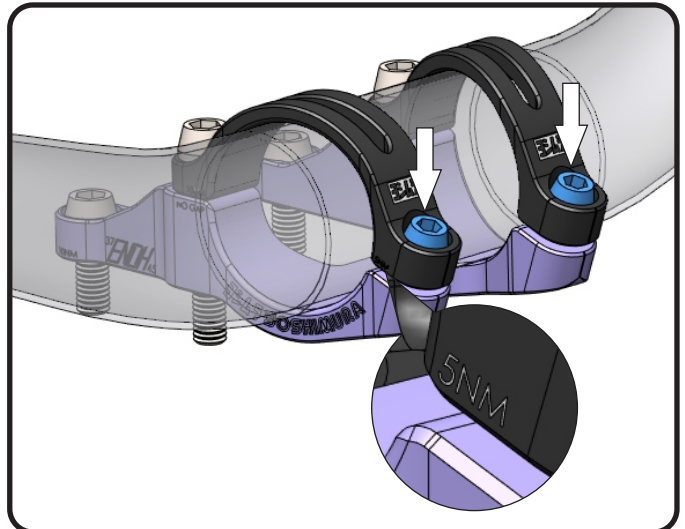

7. Check to make sure all components are secure prior to riding.