



YOSHIMURA

RESEARCH&DEVELOPMENT OF AMERICA, INC.

5420 DANIELS STREET SUITE A, CHINO, CA 91710 · (800) 634-9166 · (909) 628-4722 · FAX (909) 591-2198

www.yoshimura-rd.com

INS-07-K

YOSHIMURA RS2 LOW VOLUME INSERT KIT

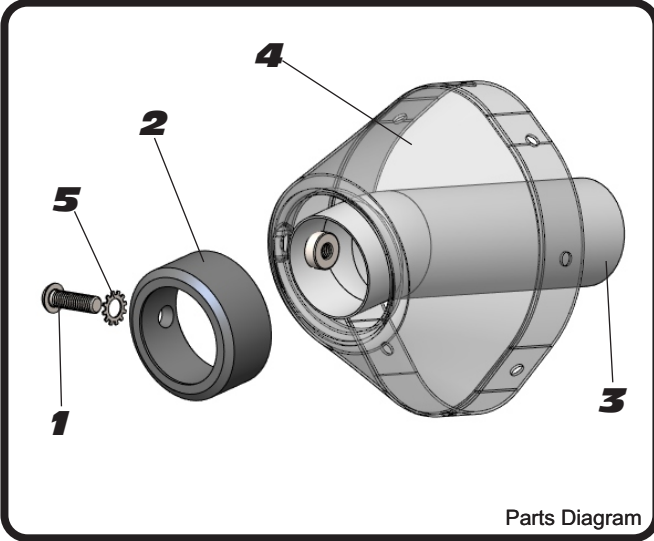

NO.	DESCRIPTION	QTY	PART #
1	6mm X 18mm Button Head Cap Screw	1	M6X18BHS
2	RS2 Ring 1.625"	1	DS4-RING-1625-1
3	RS2 Low Volume Insert	1	INS-I
4	Yoshimura Exhaust	**	**
5	6mm Tooth Lock Washer	1	6MMLCKWSHR-TH

- 1 Remove muffler from tailpipe.
- 2 Insert the front insert into the tailpipe.
- 3 Reinstall the muffler.
- 4 Insert the rear insert into the end of the muffler and secure using the small allen head bolt and lock washer.

NOTE: It is recommended that a low strength "Loc-tite" is used on the small allen head bolt.



YOSHIMURA

RESEARCH&DEVELOPMENT OF AMERICA, INC.

5420 DANIELS STREET SUITE A, CHINO, CA 91710 · (800) 634-9166 · (909) 628-4722 · FAX (909) 591-2198

www.yoshimura-rd.com

INS-07-K

YOSHIMURA RS2 LOW VOLUME INSERT KIT

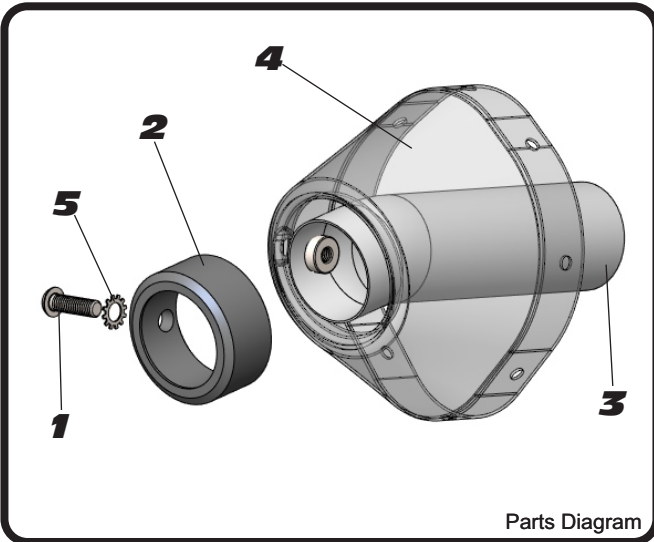

NO.	DESCRIPTION	QTY	PART #
1	6mm X 18mm Button Head Cap Screw	1	M6X18BHS
2	RS2 Ring 1.625"	1	DS4-RING-1625-1
3	RS2 Low Volume Insert	1	INS-I
4	Yoshimura Exhaust	**	**
5	6mm Tooth Lock Washer	1	6MMLCKWSHR-TH

- 1 Remove muffler from tailpipe.
- 2 Insert the front insert into the tailpipe.
- 3 Reinstall the muffler.
- 4 Insert the rear insert into the end of the muffler and secure using the small allen head bolt and lock washer.

NOTE: It is recommended that a low strength "Loc-tite" is used on the small allen head bolt.