



YOSHIMURA

RESEARCH&DEVELOPMENT OF AMERICA, INC.

5420 DANIELS STREET STE A, CHINO CA. 91710 · (800) 634-9166 · (909) 628-4722 · FAX (909) 591-2198

www.yoshimura-rd.com

RS-12 REPACK KIT

REPACK-RS12-P37



NO.	DESCRIPTION	QTY	PART #
1	Packing Kit	1	PACKING37
2	Stainless Steel Rivets	7	C3-RIVET
3	Stainless Steel Rivet Band	1	RBYM1
4	RS12 Decal	1	RS12-NB005R

CAUTION: Exhaust system can be extremely hot. Let motorcycle cool down before beginning installation. Always wear hand and eye protection and take precautionary measures to avoid injury.

NOTE: Read through all instructions before beginning installation.

WARNING: It is recommended that you wear a mask, proper eye protection, and gloves while disassembling and repacking the muffler. Fiberglass may irritate your eyes and skin.

Tools Required

Drill
3/16" Drill Bit
Rubber Hammer
Rivet Gun
Sharp Punch
Steel Hammer
Metal Rod or Long Screw Driver

Removal

1. Use a sharp punch and steel hammer to punch out the center of each rivet on the endcap assembly.
2. Using the 3/16" drill bit and drill, drill through the center of each of the rivets. Do not remove carbon fiber endcap rivets.

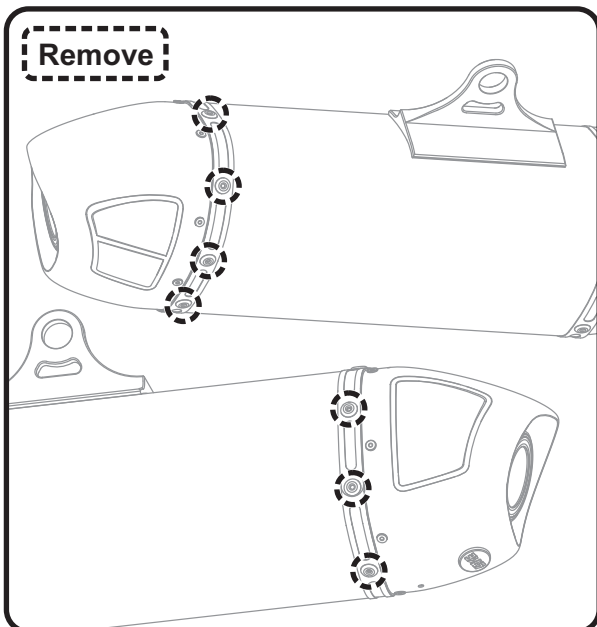

3. Carefully remove endcap assembly by pulling outward and remove old packing.

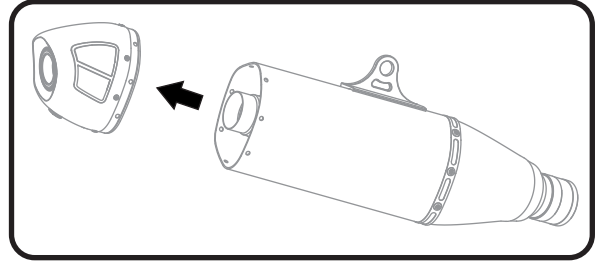

4. Remove baffle and clean carbon buildup. Inspect stainless steel mesh wrap on baffle.

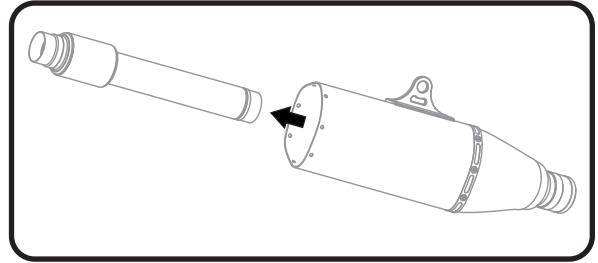

Installation

1. Re-install baffle into muffler.
2. Using a long screw driver or metal rod, evenly pack muffler with new packing around the baffle using the supplied packing. Fill remaining packing fibers into endcap around the endcap inlet. Be sure to use all of the supplied packing.

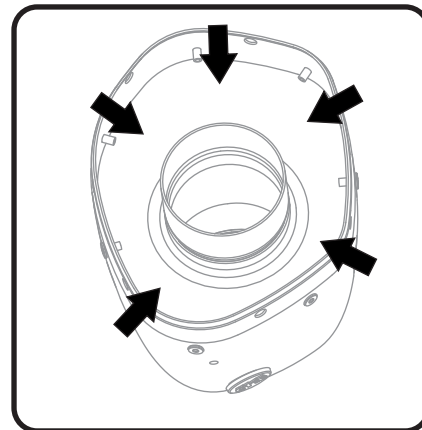

3. Re-install endcap assembly and align rivet holes.
4. Using the new rivet band, pre-install all rivets making sure that the rivet band holes are aligned. Rivet in the order shown below.

Note: The beginning and end of the rivet band will overlap when installing the last rivet.

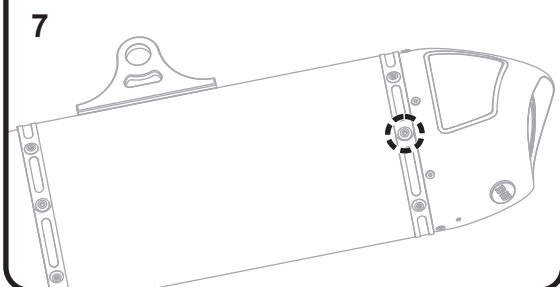
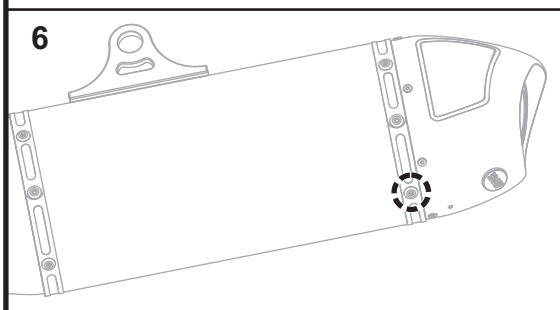
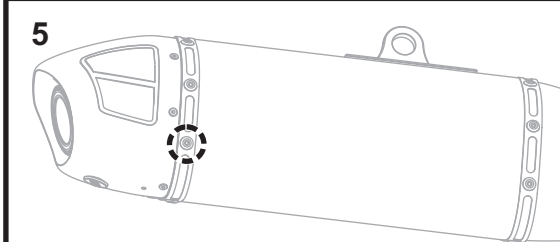
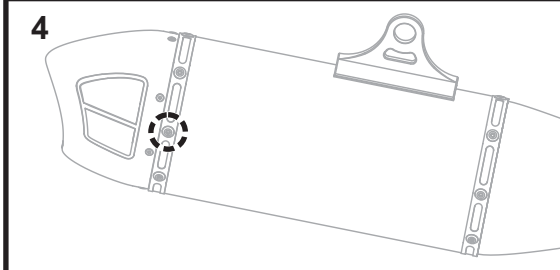
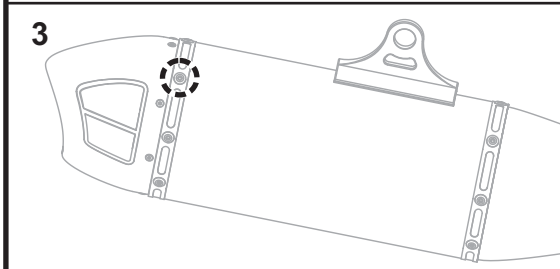
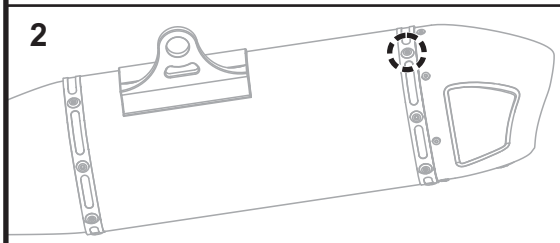
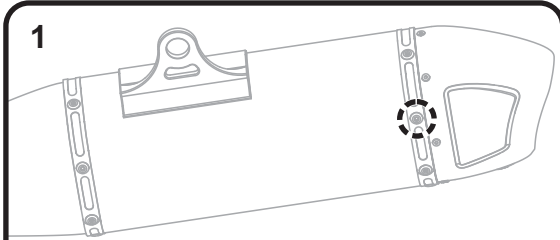

5. Remove endcap and canister decals. Clean surface thoroughly and apply new muffler decals onto muffler.
6. Before starting the motorcycle, check that all hardware is tight. If any problem is found, please carefully follow through the installation steps again. If problem still persists, please call Yoshimura Technical Department at (800) 634-9166 / in CA (909) 628-4722.