



YOSHIMURA

RESEARCH&DEVELOPMENT OF AMERICA, INC.

5420 DANIELS STREET SUITE A, CHINO, CA 91710 · (800) 634-9166 · (909) 628-4722 · FAX (909) 591-2198

www.yoshimura-rd.com

SA-17-K YOSHIMURA TEC-SD10 SPARK ARRESTOR KIT

Not for use with Carbon Fiber Sleeve

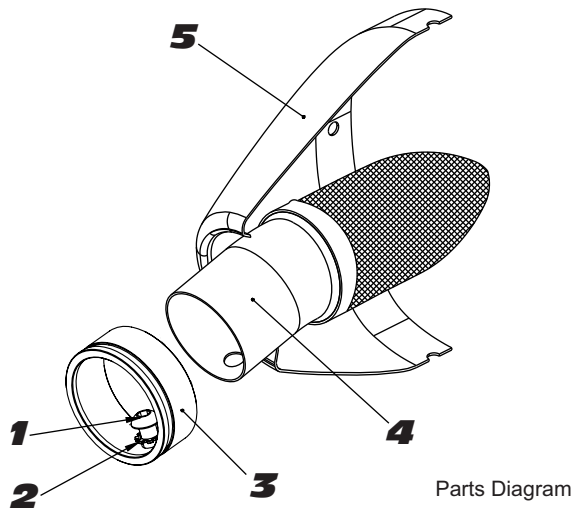

Parts Diagram

NO.	DESCRIPTION	QTY	PART #
1	6mm X 14mm Button Head Cap Screw	1	M6X14BHS
2	6mm Lock Washer	1	6MMLCKWSHR-TH
3	RS4 Spark Arrester Ring 1.500"	1	RS4A-RING-1500
4	TEC-SD10 Spark Arrester	1	TEC-SD10
5	USFS Label	1	17082
6	Yoshimura Exhaust	**	**

- Using a 4mm Allen key, remove the bolt that secures the aluminum ring and spark arrester to the muffler (see Parts Diagram for location).
- Remove the spark arrester from the muffler.
- Using a wire brush, remove carbon deposits from spark arrester screen. Inspect the screen for excessive wear or damage. If spark arrester is excessively worn or damaged, the spark arrester must be replaced. Cleaning and inspection should be performed after every 60 hours of use.
CAUTION: Gloves and safety glasses should be worn while cleaning spark arrester.
- Re-install spark arrester and aluminum ring. Torque the spark arrester securing bolt to 1.0 kg-m (7.3 lb-ft). (NOTE: It is recommended that a low strength "Loc-tite" is used on the spark arrester securing bolt.)



YOSHIMURA

RESEARCH&DEVELOPMENT OF AMERICA, INC.

5420 DANIELS STREET SUITE A, CHINO, CA 91710 · (800) 634-9166 · (909) 628-4722 · FAX (909) 591-2198

www.yoshimura-rd.com

SA-17-K YOSHIMURA TEC-SD10 SPARK ARRESTOR KIT

Not for use with Carbon Fiber Sleeve

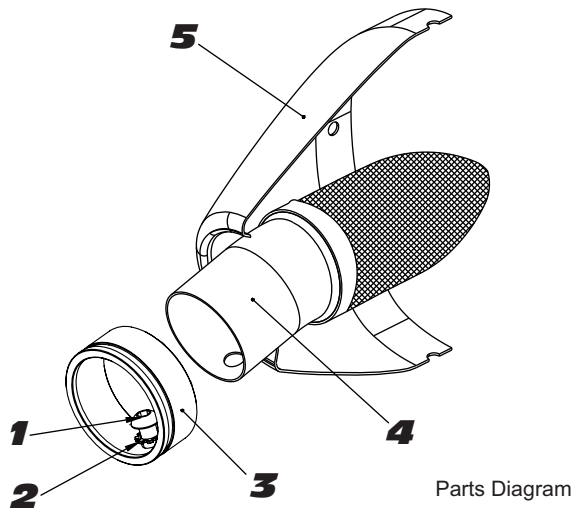

Parts Diagram

NO.	DESCRIPTION	QTY	PART #
1	6mm X 14mm Button Head Cap Screw	1	M6X14BHS
2	6mm Lock Washer	1	6MMLCKWSHR-TH
3	RS4 Spark Arrester Ring 1.500"	1	RS4A-RING-1500
4	TEC-SD10 Spark Arrester	1	TEC-SD10
5	USFS Label	1	17082
6	Yoshimura Exhaust	**	**

- Using a 4mm Allen key, remove the bolt that secures the aluminum ring and spark arrester to the muffler (see Parts Diagram for location).
- Remove the spark arrester from the muffler.
- Using a wire brush, remove carbon deposits from spark arrester screen. Inspect the screen for excessive wear or damage. If spark arrester is excessively worn or damaged, the spark arrester must be replaced. Cleaning and inspection should be performed after every 60 hours of use.
CAUTION: Gloves and safety glasses should be worn while cleaning spark arrester.
- Re-install spark arrester and aluminum ring. Torque the spark arrester securing bolt to 1.0 kg-m (7.3 lb-ft). (NOTE: It is recommended that a low strength "Loc-tite" is used on the spark arrester securing bolt.)